

Differential Pressure By-Pass Valve



519 series



BS EN ISO 9001:2000
Cert. n° FM 21654



UNI EN ISO 9001:2000
Cert. n° 0003



519709A



519599A

Function

The differential pressure by-pass valve is used in systems with a fixed speed circulating pump supplying several zones controlled by two way zone valves. This valve ensures that the head pressure of the pump is proportional to the number of two way valves being closed. It will bypass the differential pressure created by the pump as the zone valves close, thus eliminating water hammer noise.

Product range

Code 519502A Adjustable differential pressure by-pass valve with graduated scale, flow up to 9 gpm _____ Size 3/4" Male NPT x 3/4" NPT Male outlet
 Code 519599A Adjustable differential pressure by-pass valve with graduated scale, flow up to 9 gpm _____ Size 3/4" Sweat x 3/4" Sweat outlet
 Code 519600A Adjustable differential pressure by-pass valve with graduated scale, flow up to 40 gpm _____ Size 1" Female NPT x 1" Male NPT outlet
 Code 519609A Adjustable differential pressure by-pass valve with graduated scale, flow up to 40 gpm _____ Size 1" Female NPT x 1" sweat outlet
 Code 519700A Adjustable differential pressure by-pass valve with graduated scale, flow up to 45 gpm _____ Size 1 1/4" Female NPT x 1 1/4" Female NPT outlet
 Code 519709A Adjustable differential pressure by-pass valve with graduated scale, flow up to 45 gpm _____ Size 1 1/4" Female NPT + 1 1/4" sweat outlet

Technical specifications

Materials

Body: brass
 Valve plug: brass
 Valve plug gasket: EPDM
 O-Ring seals: EPDM
 Union seals: asbestos free NBR
 Control knob: ABS
 Spring: stainless steel

Performance

Medium: water, glycol solutions
 Max percentage of glycol: 30%
 Temperature range: 32-230°F (0-110°C)
 Maximum working pressure: 150 psi (10 bar)
 Flow rates: 3/4" flow up to 9 gpm
 1" flow up to 40 gpm
 1 1/4" flow up to 45 gpm
 Setting range: 1 - 6 m w.g. (2 - 10 psi)

Dimensions

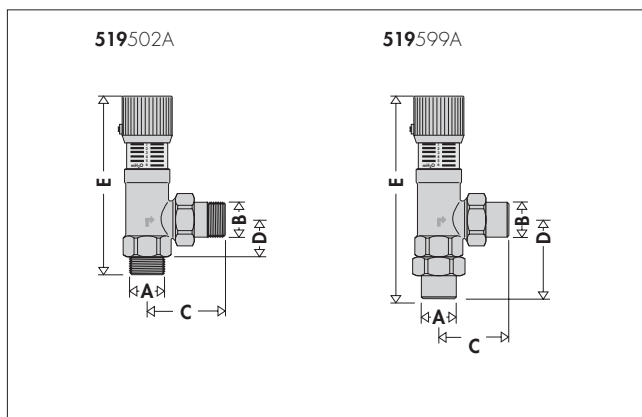

Code	A	B	C	D	E	Weight (lb)
519502A	3/4" MNPT	3/4" MNPT	2 1/4"	1 7/8"	5"	1
519599A	3/4" SWT	3/4" SWT	2 1/8"	2 1/2"	5 9/16"	1

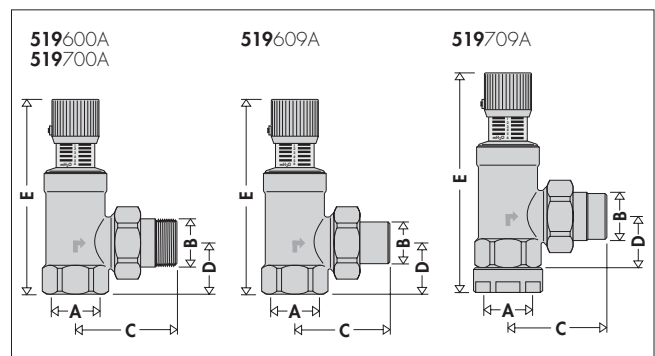

Code	A	B	C	D	E	Weight (lb)
519600A 519700A	1" FNPT	1" MNPT	3 13/16"	2 1/16"	6 5/8"	1.4
519609A	1" FNPT	1" SWT	2 13/16"	2 1/16"	6 5/8"	1.4
519700A	1 1/4" FNPT	1 1/4" MNPT	3 15/16"	2 11/16"	7 3/8"	1.5
519709A	1 1/4" FNPT	1 1/4" SWT	3"	2 11/16"	7 3/8"	1.5

Operating principle

When the spring (1) compression is adjusted using the control knob (2), the force balance acting on the valve plug (3) changes, thus modifying the threshold pressure value of the valve. The valve plug opens, activating the by-pass circuit, only when it is subjected to a differential pressure sufficient to generate a thrust greater than the thrust exerted by the spring. This allows the flow discharge through the outlet (4), limiting the difference in pressure between the two points in the system where the valve is fitted.

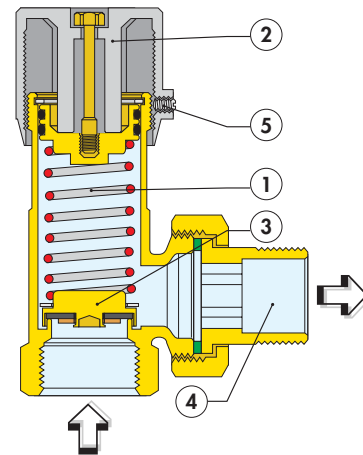

System operation

The job of the differential pressure by-pass valve is to maintain the pump operating point as close as possible to its nominal value (point A on the graph shown below). If the by-pass valve is not used, when the flow rate in the circuit decreases due to partial closure of the two-way zone valves, the head loss in the circuit increases, point B.

The by-pass valve, set to the nominal head value of the pump, limits the increase in pressure, by-passing the flow rate ΔG . This behavior is guaranteed at any closing condition of the system two-way zone valves. In fact, once the position of the valve control knob has been established, the threshold pressure value is more or less constant as the discharge flow rate varies (see hydraulic characteristic diagrams).

A proper valve sizing must guarantee a sufficient flow rate by-pass to keep the pump at its nominal operating point in all system operating conditions, for example when the first zone valves are closed.

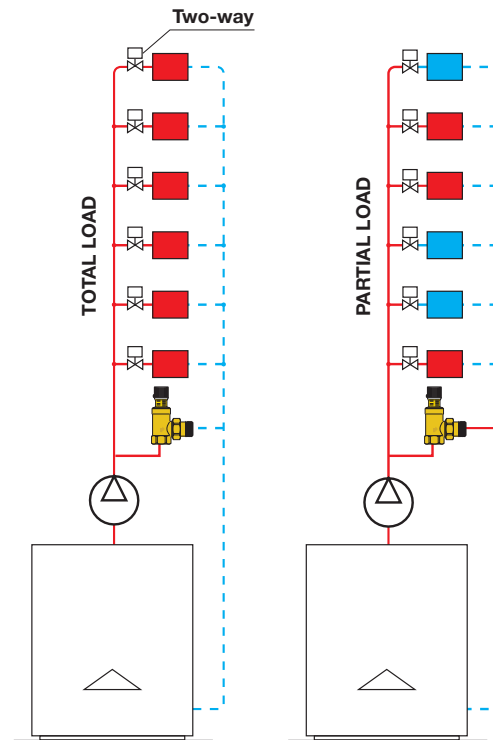
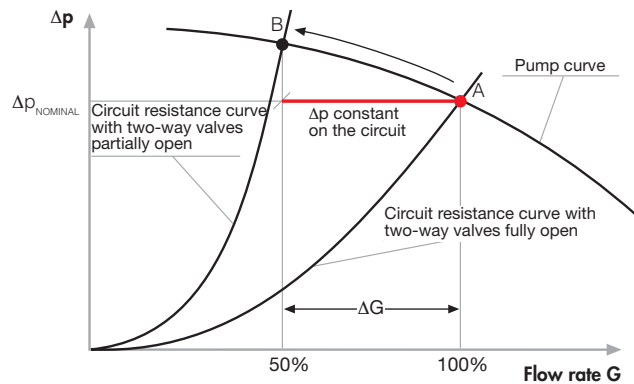

Setting

To regulate the valve, turn the knob to the required value on the graduated scale: the values correspond to the differential pressure in psi or meters w.g. to open the by-pass.

For a quick setup adjustment of the differential pressure by-pass valve, use the following manual method. As an example, a hydronic system with several zone valves: the system must be operating, the zone valves must be fully open and the by-pass valve must be set to the maximum value (a) (clockwise). Gradually open the differential pressure by-pass valve using the control knob (counterclockwise). Use a thermometer, or simply your hand, to check that the hot water is flowing into the by-pass circuit (b). As soon as a rise in the temperature is noted, turn control knob (clockwise) one half turn closed so hot water stops flowing into the by-pass (c). Lock the knob in this position (d) with the locking screw.

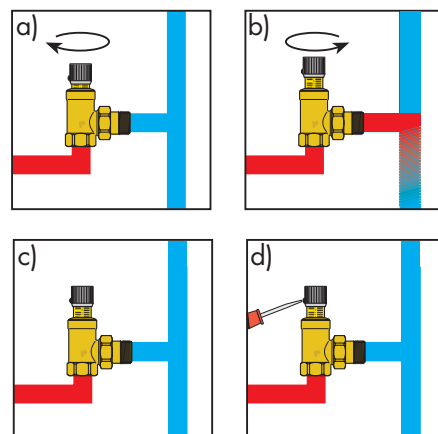

Hydraulic characteristics

code 519502A - 519599A (3/4")

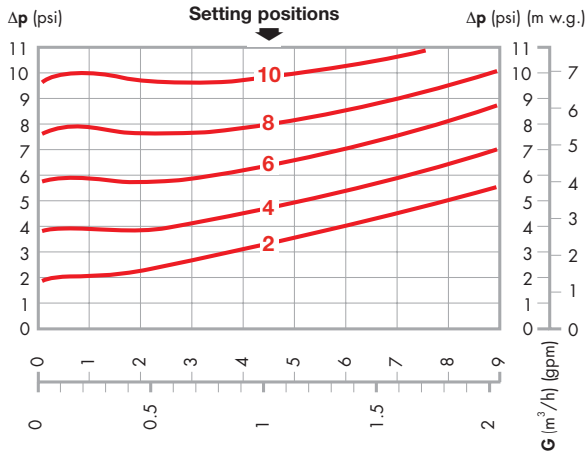

code 519600A - 519609A (1")

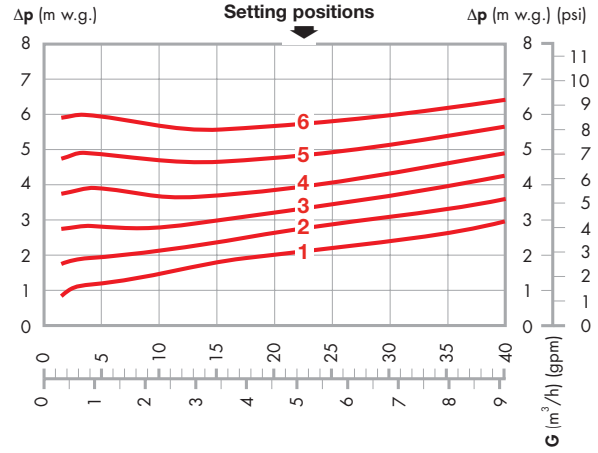

code 519700A - 519709A (1 1/4")

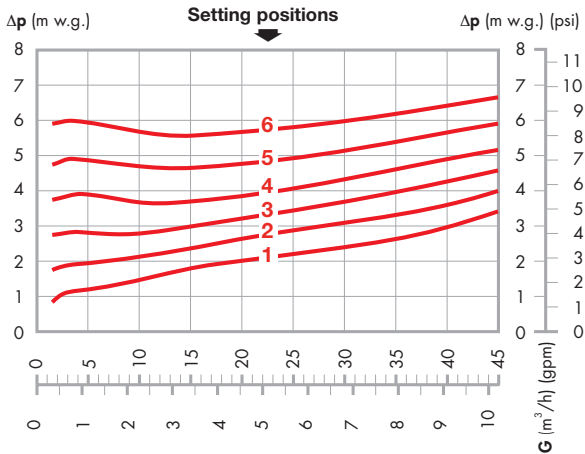

Installation

The differential pressure by-pass valve can be fitted in any position, respecting the flow direction indicated by the arrow on the valve body.

In systems with a traditional boiler it is normally fitted between the system flow and return ends, which allows the control of the pressure and the passage of a minimum flow through the heat generator.

In systems with a condensation boiler, it is preferable to fit the by-pass directly between the upstream and downstream sections of the pump, as this allows a higher ΔT in the circuit, with lower return temperatures and therefore better operation of the system. In the event of high by-pass flow rate levels, it is recommended to fit the valve between the flow and return ends of each column, rather than fitting a number of valves in parallel at the central boiler.

Application diagrams

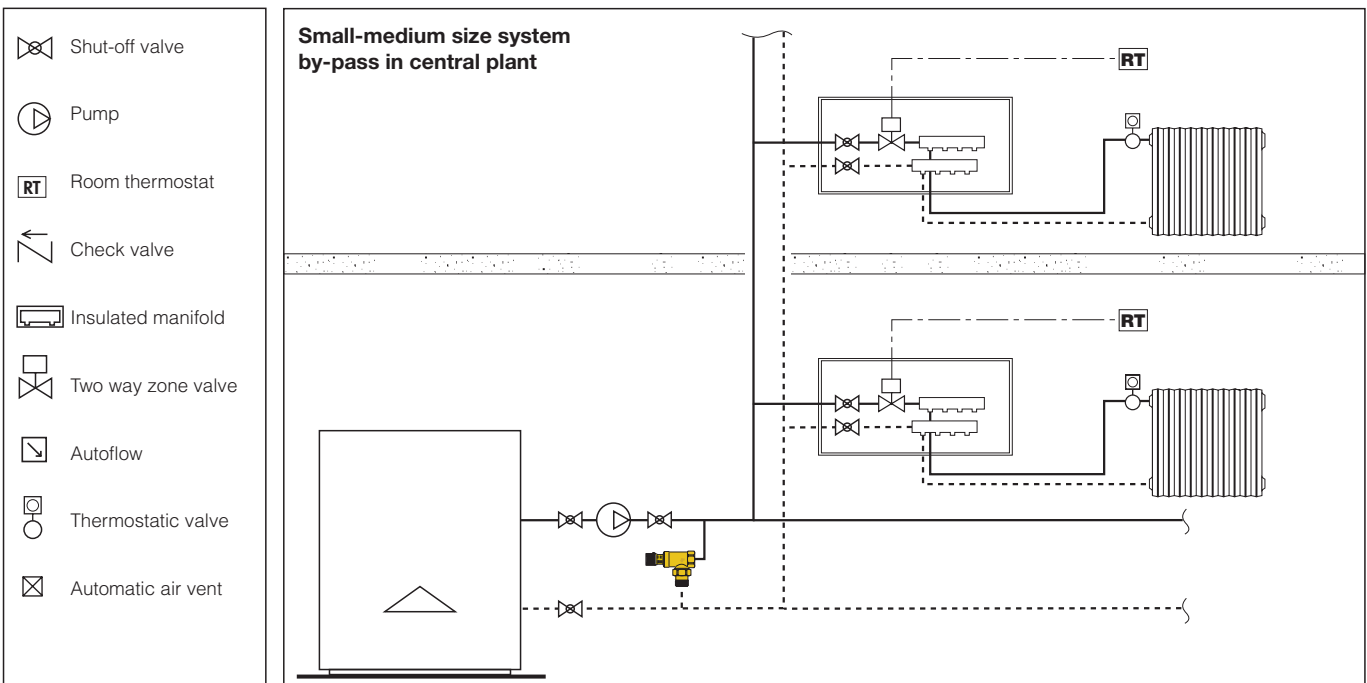

**Medium-large size system
by-pass on top of risers**

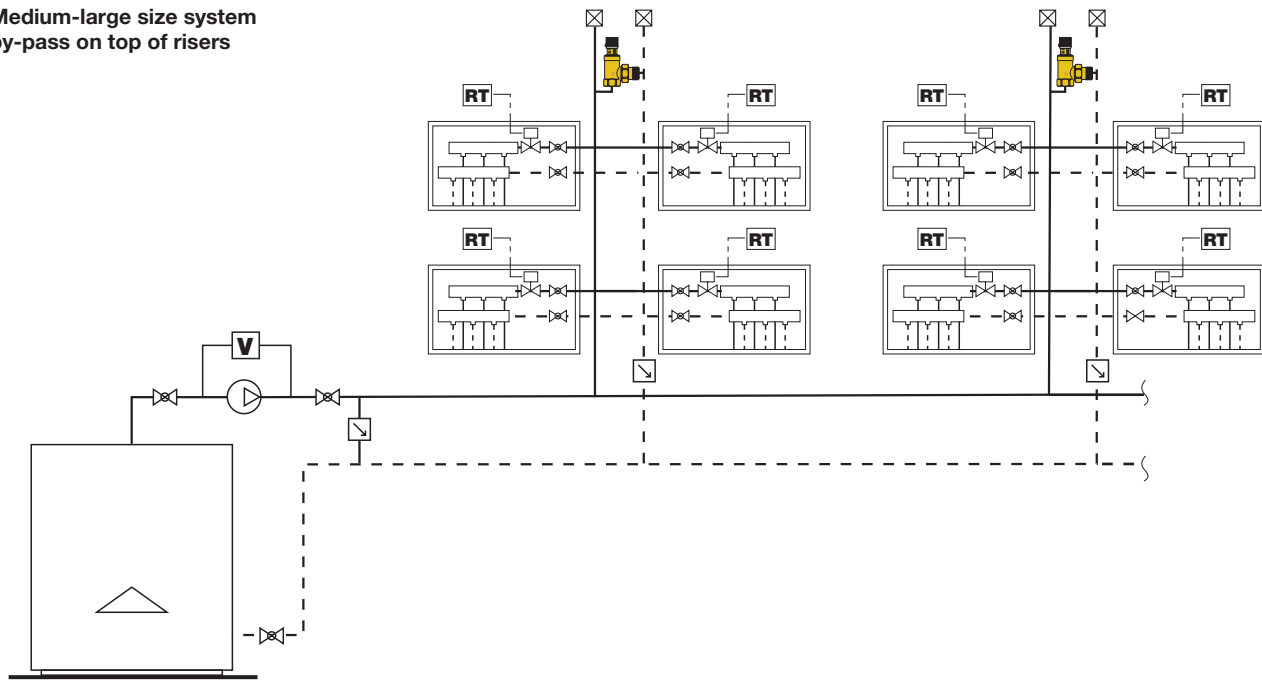

Chilled water system, central by-pass

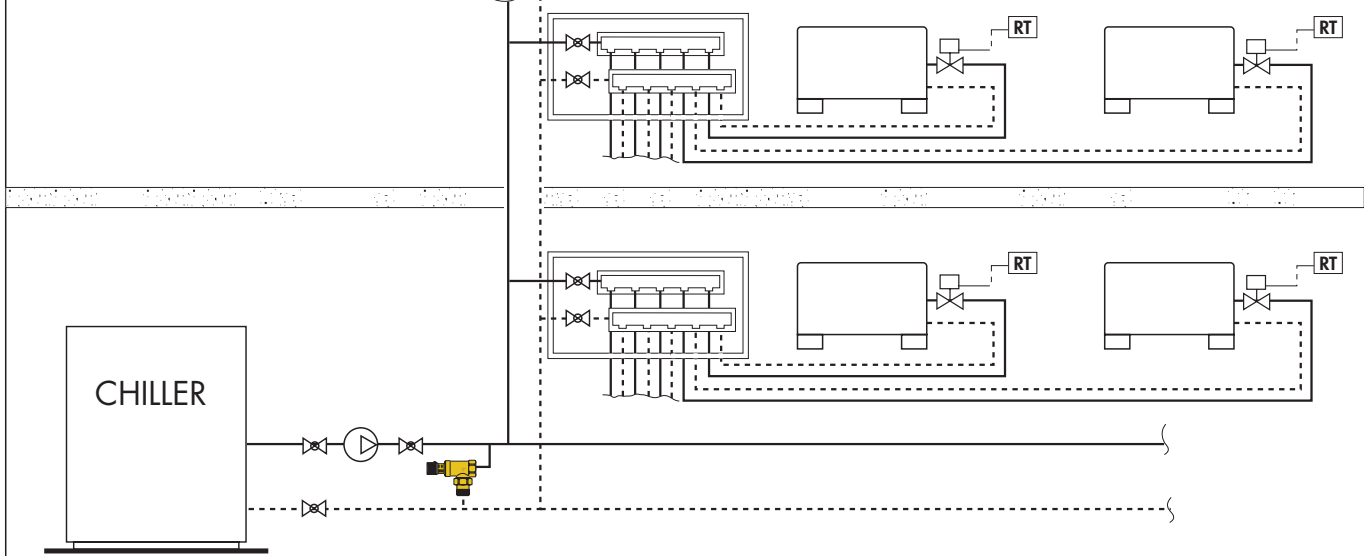

SPECIFICATION SUMMARIES

519 series

Differential pressure by-pass valve. Threaded connections 3/4" MNPT x 3/4" MNPT outlet, 3/4" Sweat x 3/4" Sweat outlet 1" FNPT x 1" MNPT outlet, 1" FNPT x 1" sweat outlet, 1 1/4" FNPT x 1 1/4" MNPT outlet and 1 1/4" FNPT + 1 1/4" sweat outlet. Brass body. Brass valve plug. EPDM valve plug gasket. EPDM O-Ring seals. Asbestos free NBR union seals. ABS control knob. Stainless steel spring. Medium: water, glycol solutions. Maximum percentage of glycol 30%. Temperature range 32–230°F (0–110°C). Maximum working pressure 150 psi (10 bar). Setting range is 1 - 6 m w.g. (2–10 psi) and 3/4" flow up to 9 gpm (1" flow up to 40 gpm and 1 1/4" flow up to 45 gpm).

We reserve the right to change our products and their relevant technical data, contained in this publication, at any time and without prior notice.

