

Automatic air vent for heating systems and radiators

series 501 - 5022 - 5026 - 5027 - 5080



cert. n° 0003
ISO 9001

01090/03 NA



Function

Series 501

Extra high capacity float type automatic air vent designed for use on large pipes where large quantity of air is required to be released from the system.

Series 5022 - 5023

High capacity float type automatic air vent designed for use on manifolds or pipes in sealed heating systems. Check valve on 5023 series allows an easy replacement of air vent without purging the system.

Series 5026 - 5027

Float type automatic air vent designed to vent air that is released from the water while being heated. Check valve on 5027 series allows an easy replacement of air vent without purging the system.

Series 5080

Radiator air vent valve designed to remove automatically any air trapped inside the heat emitters both during the filling of the system and in normal operation.

Product range

Series 501	Extra high capacity automatic air vent	Size 3/4"
Series 5022	High capacity automatic air vent	Size 1/2"
Series 5023	High capacity automatic air vent with check valve	Size 1/2"
Series 5026	Automatic air vent	Sizes 1/8" - 1/4"
Series 5027	Automatic air vent with check valve	Sizes 1/8" - 1/4"
Series 5080	Automatic hygroscopic air vent for radiators	Size 1/8"

Technical specification

series ↔	501	5022 - 5023	5026 - 5027	5080
Materials				
Body:	brass	brass	brass	chrome plated brass
Float:	stainless steel	PP	PP	-
Mechanism stem:	stainless steel	brass	-	-
Mechanism seal:	Viton	EPDM	Silicon rubber	-
Seals:	EPDM	EPDM	EPDM	EPDM
Performance				
Max working pressure:	230 psi (16 bar)	150 psi (10 bar)	150 psi (10 bar)	150 psi (10 bar)
Max venting pressure:	90 psi (6 bar)	60 psi (4 bar)	90 psi (6 bar)	-
Max working temperature:	-4÷250°F (-20÷120°C)	250°F (120°C)	240°F (115°C)	212°F (100°C)
Connections:	inlet 3/4" NPT female exhaust 3/8" female straight	1/2" NPT male	1/8" and 1/4" NPT male	1/8" NPT male

Dimensions

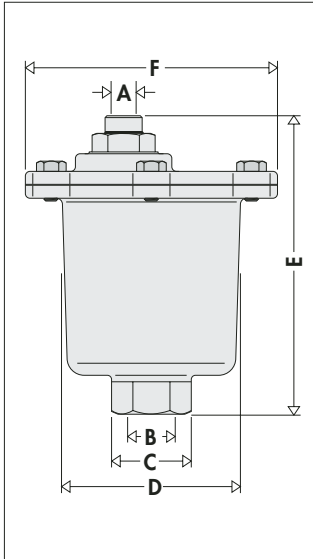

Code	A	B	C	D	E	F
501502A	3/8"	3/4"	1 9/16"	3 13/16"	6 1/4"	5 3/16"

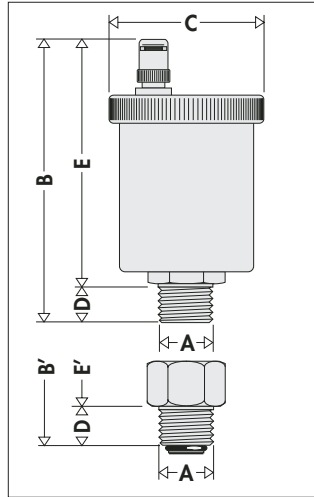

Code	A	B	C	D	E
502243A	1/2"	4"	2 3/16"	1/2"	2 1/2"

Code	A	B'	C	D	E'
502343A	1/2"	4 3/4"	2 3/16"	1/2"	3 1/4"

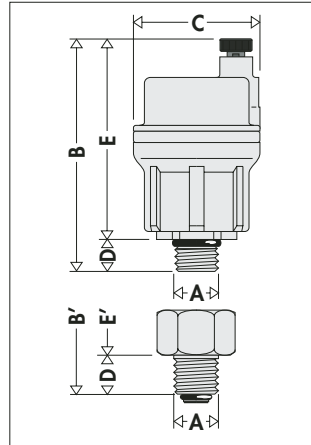

Code	A	B	C	D	E
502610A	1/8"	3 1/16"	1 9/16"	7/16"	2 5/8"
502620A	1/4"	3 1/16"	1 9/16"	1/2"	2 5/8"

Code	A	B'	C	D	E'
502710A	1/8"	4"	1 9/16"	1/2"	3 3/8"
502720A	1/4"	4"	1 9/16"	1/2"	3 3/8"

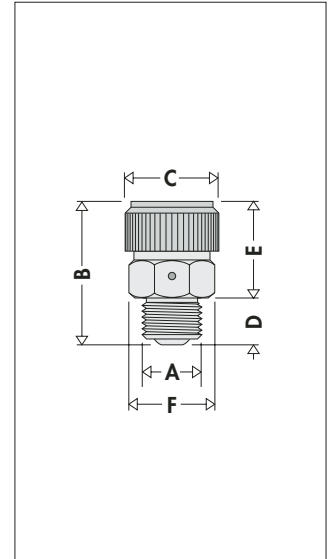

Code	A	B	C	D	E	F
508013A	1/8"	1 1/4"	1 11/16"	7/16"	13/16"	9/16"

Construction details

501

• Stainless steel components.

The components used for the elimination of air like float, sliding guide zones, spring and mechanism stem are made of stainless steel. In this way they minimize the friction and ensure maximum reliability.

• Protection device

The venting air is passed through a forced passage and a filter with a thin mesh strainer. This arrangement avoids the danger of leakage due to debris, that can be deposited between the seat and the mechanism.

• High venting capacity

The size of this deaerator makes it suitable for applications on large pipes, particularly on horizontal sections (distribution manifolds in central boilers applications) or wherever it is required to release large quantities of air from the system.

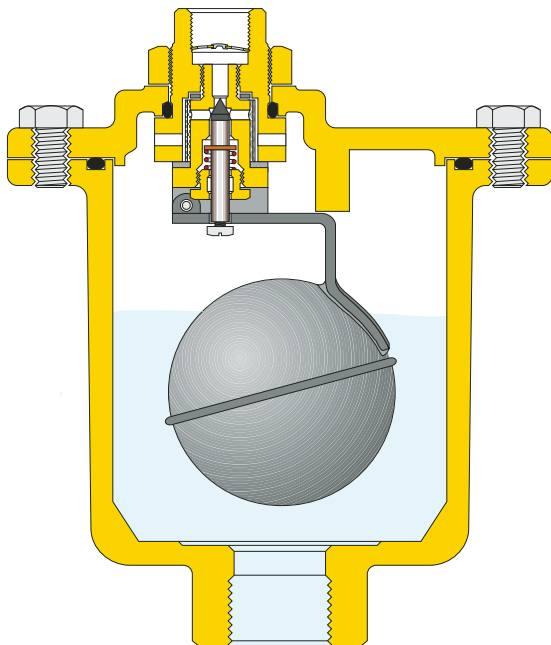

• Threaded outlet

At the top of the device there is a 3/8" Female threaded exhaust connection which is suitable for connecting a conveying pipe.

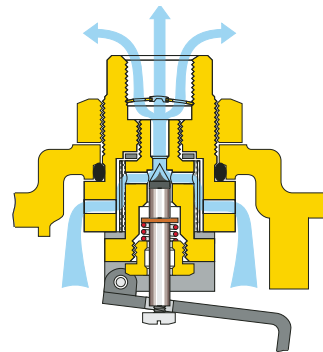

Installation

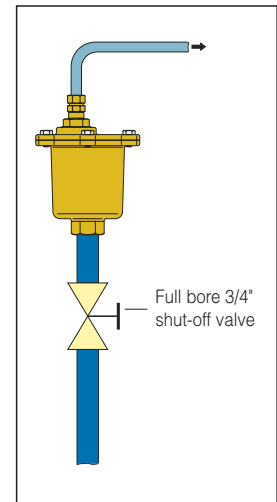

Air flow

Flow rate

SCFM

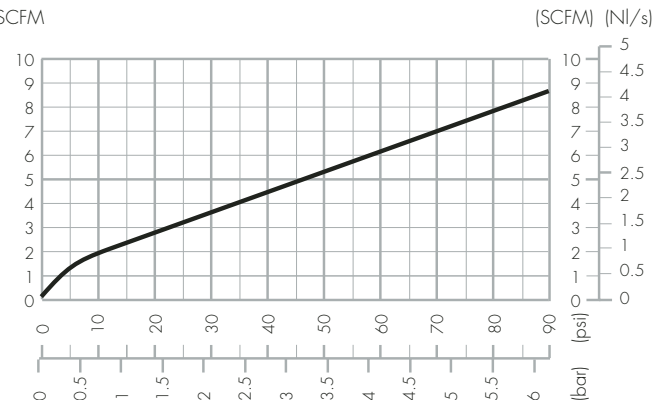

5022 - 5023

• Operating mechanism

The air is vented by means of a stem mechanism protected against debris from outside.

• Chamber

The height of the chamber for float movement is designed to collect high air volumes from water.

• Hygroscopic cap

A safety hygroscopic cap automatically closes the air discharge in case of contact with water.

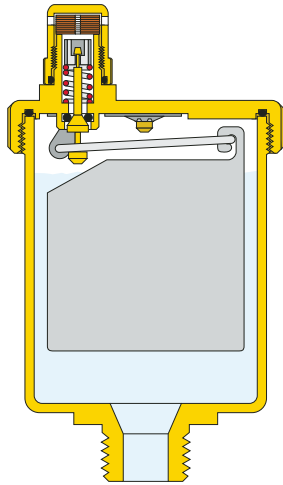

5026 - 5027

• Operating mechanism

The function of this device is guaranteed by an operating mechanism made of silicon rubber specially designed to vent when pressure reaches high values in the system.

• Antivibration and antirotation system on the float

This system guarantees that in the rest position the air relief valve will not be affected by any movement of the float.

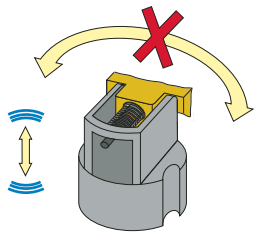
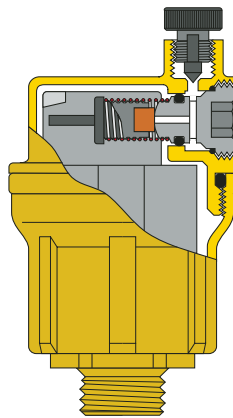

• Check valve

The check valve on 5023 and 5027 series allows an easy maintenance or substitution of the valve without purging the system.

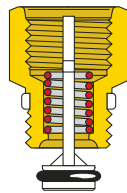

5080

Valve code 5080 can be used manually or automatically.

The **automatic** discharge is based on the property of the cellulose fibre discs forming the seal cartridge.

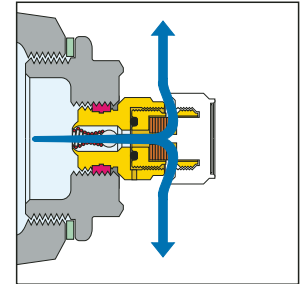
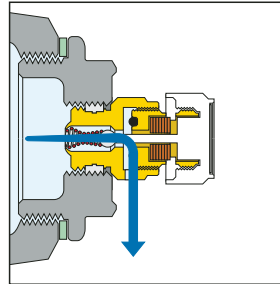
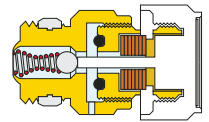

The **manual** discharge position is achieved by unscrewing the knob **approx. one turn**. Typical use of this method is when refilling the system.

The **automatic** discharge position is achieved with the knob fully closed.

The hygroscopic discs increase their volume by 50% when they are immersed in water.

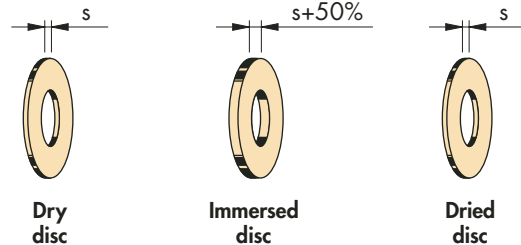

In this way, when the system is operating under normal conditions, the discs are immersed and, thanks to their increase in volume, they close the valve. However, when air is present, the discs dry out and allow the air to vent.

The hygroscopic discs close very quickly, in just a few seconds. The drying times are such that there are no problems with the cycle of formation and elimination of air.

Drying times

Water temperature	°C	40	50	60	70	80	90	100
	°F	104	122	140	158	176	194	212
Times in hours		6	5	2 1/2	1 1/2	1	1/2	1/4

Air flow

Flow rate

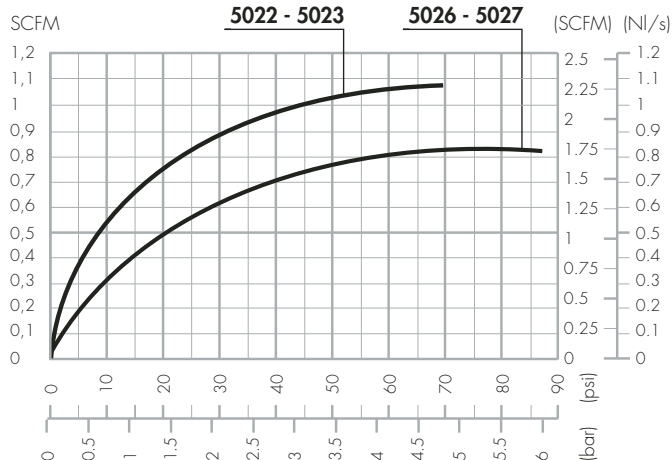

Replaceable cartridge

The valve is constructed in such a way that the part containing the hygroscopic discs can easily be replaced without having to empty the heat emitter. This may be necessary because the discs can deteriorate in time if there is unfiltered or hard water present.

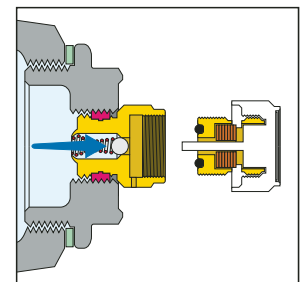

In any case, it is advisable to replace the disc cartridge at least every 36 months.

SPECIFICATION SUMMARIES

Series 501

Automatic air vent for heating systems. 3/4" F threaded connection. Brass body and cover. VITON operating mechanism seal. Stainless steel float components and cover bolts. Seat and seal protected by a thin-mesh filter. EPDM seals. Maximum working pressure: 230 psi (16 bar). Maximum venting pressure: 90 psi (6 bar). Maximum working temperature: 250°F (120°C). With 3/8" F discharge connection.

Series 5022

Automatic air vent. 1/2" M threaded connection. Brass body and cover. Brass valve stem. EPDM seals. Maximum working pressure: 150 psi (10 bar). Maximum venting pressure: 60 psi (4 bar). Maximum working temperature: 250°F (120°C). Vertical relief.

Series 5023

Automatic air vent with check valve. 1/2" M threaded connection. Brass body and cover. Brass valve stem. EPDM seals. Maximum working pressure: 150 psi (10 bar). Maximum venting pressure: 60 psi (4 bar). Maximum working temperature: 250°F (120°C). Vertical relief.

Series 5026

Automatic air vent. 1/8" and 1/4" M threaded connections. Brass body and cover. Silicone rubber operating mechanism. EPDM seals. Maximum working pressure: 150 psi (10 bar). Maximum venting pressure: 90 psi (6 bar). Maximum working temperature: 240°F (115°C). Antirotation and antivibration system of the float. Vertical relief.

Series 5027

Automatic air vent with check valve. 1/8" and 1/4" M threaded connections. Brass body and cover. Silicone rubber operating mechanism. EPDM seals. Maximum working pressure: 150 psi (10 bar). Maximum venting pressure: 90 psi (6 bar). Maximum working temperature: 240°F (115°C). Antirotation and antivibration system of the float. Vertical relief.

Series 5080

Automatic hygroscopic radiator air vent. 1/8" M threaded connection. Nickel-plated brass body. White POM heat resistant knob. Maximum working pressure: 150 psi (10 bar). Maximum working temperature: 212°F (100°C). Replaceable hygroscopic cartridge.

We reserve the right to change our products and their relevant technical data, contained in this publication, at any time and without prior notice.



Caleffi North America, Inc.
Corporate Headquarters & Production
9850 South 54th Street / Milwaukee, WI 53132
Tel: 414.421.1000 / Fax: 414.421.2878 / www.caleffi.com
© Copyright 2003 Caleffi North America, Inc.