

# Zone valve

## series 676



cert. n° 0003  
ISO 9001



### Function

Zone valves are used to control hot and chilled water in heating and air-conditioning systems. Coupled with an electro-thermal control actuator and managed by a room thermostat, they allow automatic on/off control of the hydronic circuit on which they are installed.

Their special feature is their compact size and they can therefore be installed almost anywhere including baseboard or directly in fan-coil units.

### Product range

Zone valves are available in the following configurations:

Series 676 2-way sizes 1/2", 3/4", 1" sweat

They are coupled with electro-thermal control actuator:

Series 656 24 V (ac) with auxiliary microswitch

### Technical Characteristics

#### Valve:

Materials: - body: brass  
 - trim: brass  
 - stem: stainless steel  
 - spring: stainless steel  
 - seals: EPDM

- Medium: water, glycol solutions  
 - Max percentage of glycol: 50%  
 - Maximum working pressure: 150 psi (10 bar)  
 - Maximum temperature: 200°F (95°C)  
 - Cv rating: Cv=4.0 (Kv = 3.5)  
 - Maximum close-off: 20 psi (1.2 bar)  
 - Connections: 1/2" - 3/4" - 1" sweat with union

#### Actuator:

Type: Normally closed  
 Supply voltage: 24 VAC  
 Starting current: ≤ 1 A  
 Working current: 140 mA  
 Power consumption: 3 W  
 Level of protection: NEMA 1/IP44 in vertical position  
 Rating of micro switch: 5.0A  
 Maximum Room Temperature: 120°F (50°C)  
 Lead length: 30" (0.8 m)  
 Opening and closing time: 120 to 180 sec

### Dimensions

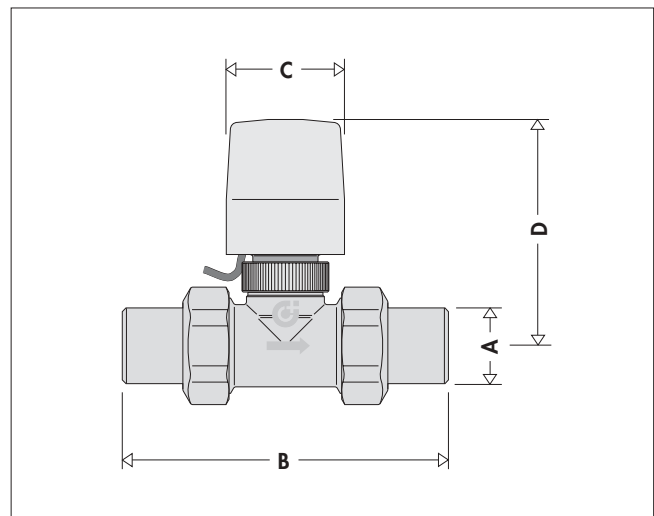

Code	A	B	C	D
676149	1/2"	3 11/16"	1 5/8"	3 3/16"
676159	3/4"	4 3/16"	1 5/8"	3 3/16"
676169	1"	5 3/8"	1 5/8"	3 3/16"

## Operating principle

When a room thermostat operates, the thermo-electric actuator causes the opening or closing of the valve actuator controlling the thermal carrier fluid.

The actuator operates via a wax expansion thermostat heated up by a PTC resistor, which automatically limits the current once reaching regime temperature.

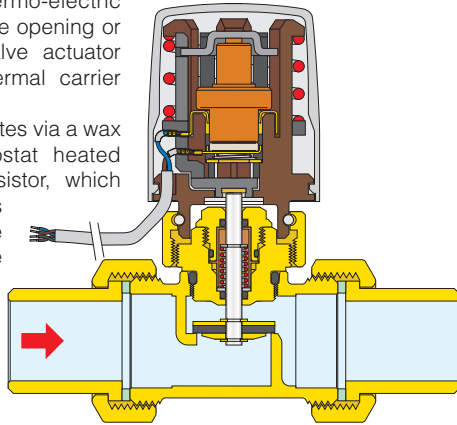

## Wiring diagram for Electro-thermal Control Actuator with micro switch

### Diagram with pump disconnected

The auxiliary microswitch can be used to switch off the pump when heat is not required and the valve is closed. If the pump's power consumption exceeds the capacity of the contacts, equal to 5.0 A, an intermediate relay should be used.

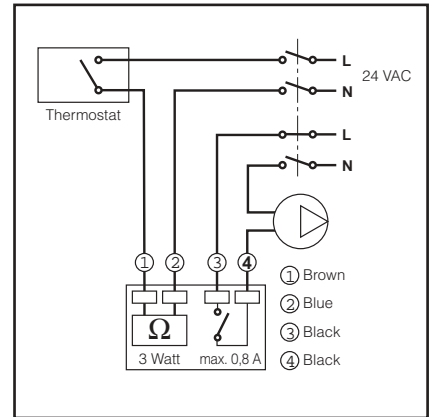

## Construction details

### Control spindle

The stainless steel control spindle has a double hydronic seal consisting of two EPDM O-rings; this means that the upper part of the unit can be replaced even when the system is operating.

### Manual opening

With the electro-thermal actuator mounted, the valve is normally closed. For manual opening, remove the electro-thermal actuator unscrewing the lower metal ring.

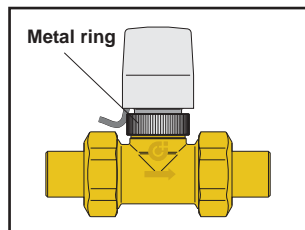

## Installation

The 2-way valve, 676 series, can be installed in the flow or return pipework.

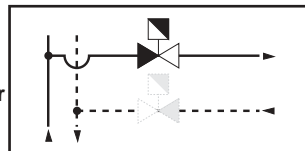

## Applications diagram

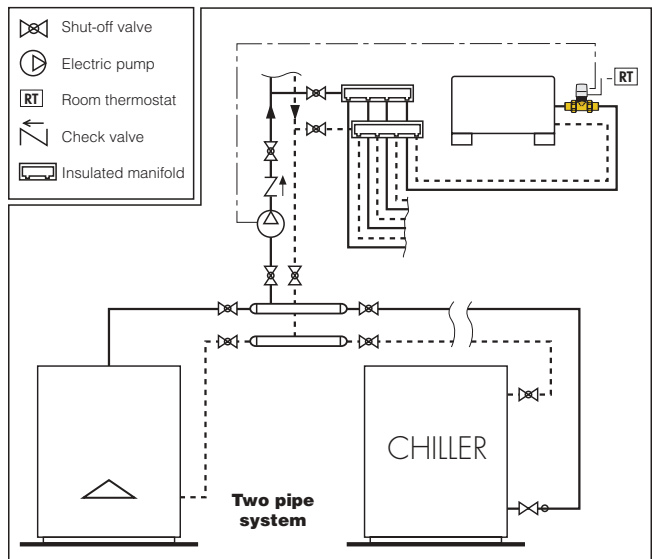

## SPECIFICATION SUMMARIES

### Series 676

2-way zone valve. Designed for thermo-electric actuator. Connections 1/2" (from 1/2" to 1") sweat, with union. Brass body. Stainless steel control stem. Control stem seal with EPDM double O-ring. ABS manual control knob. Max. working temperature 200°F (95°C). Max. working pressure 150 psi (10 bar). Max. differential pressure 18 psi (1.2 bar).

### Series 656

Thermo-electric actuator. Normally closed with auxiliary microswitch. Supply voltage: 24 V. Starting current: ≤ 1 A. Operating current: 140 mA. Power consumption: 3 W. Protection class NEMA 1/IP44 (in vertical position). Rating of the auxiliary microswitch contacts: 5.0 A. Maximum ambient temperature: 120°F (50°C). Operating time: 120±180 seconds. Length of supply cable: 30" (0,8 m).

We reserve the right to change our products and their relevant technical data, contained in this publication, at any time and without prior notice.



Caleffi North America, Inc.  
Corporate Headquarters & Production  
9850 South 54th Street / Milwaukee, WI 53132  
Tel: 414.421.1000 / Fax: 414.421.2878 / www.caleffi.com  
© Copyright 2003 Caleffi North America, Inc.