

GeoCal™ geothermal manifolds

series 110

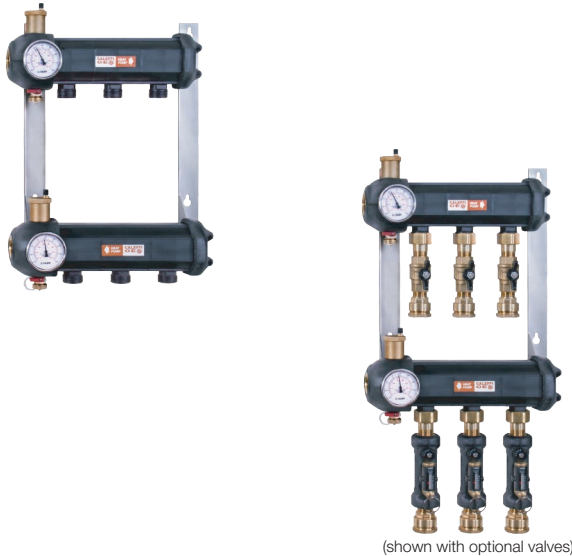

Function

The GeoCal™ pre-assembled manifold for ground-source geothermal loops offers an alternative method of piping parallel earth loops, bringing all circuits to a common manifold station without labor-intensive fusion welding. GeoCal manifolds provide significant installation, commissioning, and operational advantages. With optional 3/4" or 1" QuickSetter™ balancing valves with flowmeters and shutoff ball valves, GeoCal allows easy individual circuit balancing leading to lower pumping costs and greater system efficiency. Shutoff ball valves installed on the return manifold allows for easy individual circuit purging while minimizing purge pump size. GeoGrip™ couplings are used for connecting to polyethylene piping, either directly to the manifold or to the balancing valves and shutoff valves, making the ground earthloop installation completely free of fusion joints.

GeoCal™ pre-assembled manifold for ground-source geothermal loops, with automatic air vents, dual-scale temperature gages, fill/drain valves, supply and return manifolds, brass end caps with insulation, wall brackets with mounting hardware and labels

Product range

Series 110 GeoCal™ pre-assembled manifold2 to 8 earthloop circuit outlets 1-1/4" NPT female end connection

Technical specification

Materials:

Supply and Return manifold body: polymer PA66G30
 End fitting with air vent, fill/drain cock: brass
 End cap: brass
 Tie rods: stainless steel
 Wall mounting brackets: stainless steel

Performance:

Suitable fluids: water, ethanol*, methanol*, glycol and saline solutions
 Max. percentage of solutions:
 glycol: 50%
 ethanol: 30%
 methanol: 25%
 Max. working pressure: 90 psi (6 bar)
 Max. system test pressure: 150 psi (10 bar)
 Working temperature range:
 water, glycol and saline solutions: 15 – 140°F (-10 – 60°C)
 ethanol and methanol solutions: 15 – 85°F (-10 – 30°C)
 Ambient temperature range: -5 – 140°F (-20 – 60°C)
 Max. flow rate: 24 gpm (1.6 l/s) total all circuits
 Supply & Return manifold end connection: 1-1/4" NPT female
 Connection center distance: 4 inch (100 mm)
 Custom threaded circuit connections with EPDM mechanical seal for connecting geothermal pipe fitting, shutoff ball valves, or QuickSetter balancing valves.

*Always verify compliance with local regulations prior to use.

Product codes

Code	Description			
1107B5LA	1-1/4" NPT end	GeoCal™ Manifold	2 circuits	Left side Pipe Connections
1107C5LA			3 circuits	
1107D5LA			4 circuits	
1107E5LA			5 circuits	
1107F5LA			6 circuits	
1107G5LA			7 circuits	
1107H5LA			8 circuits	
1107B5RA			1-1/4" NPT end	
1107C5RA	3 circuits			
1107D5RA	4 circuits			
1107E5RA	5 circuits			
1107F5RA	6 circuits			
1107G5RA	7 circuits			
1107H5RA	8 circuits			

Dimensions

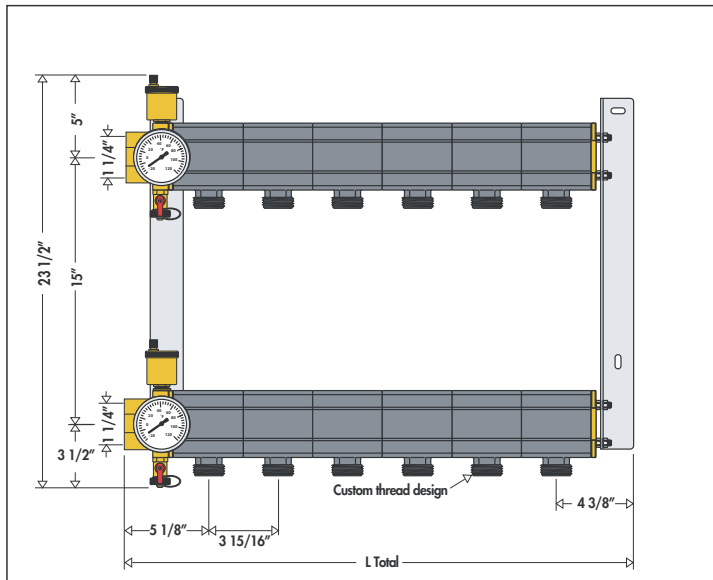

Code (Left/Right)	No. Outlets	L Total	Weight (lb)
1107B5LA/5RA	2	13 1/4"	16.6
1107C5LA/5RA	3	17 1/4"	18.2
1107D5LA/5RA	4	21 1/4"	19.8
1107E5LA/5RA	5	25 1/4"	21.5
1107F5LA/5RA	6	29 1/4"	23.1
1107G5LA/5RA	7	33 1/4"	24.8
1107H5LA/5RA	8	37 1/4"	26.4

Characteristic Components

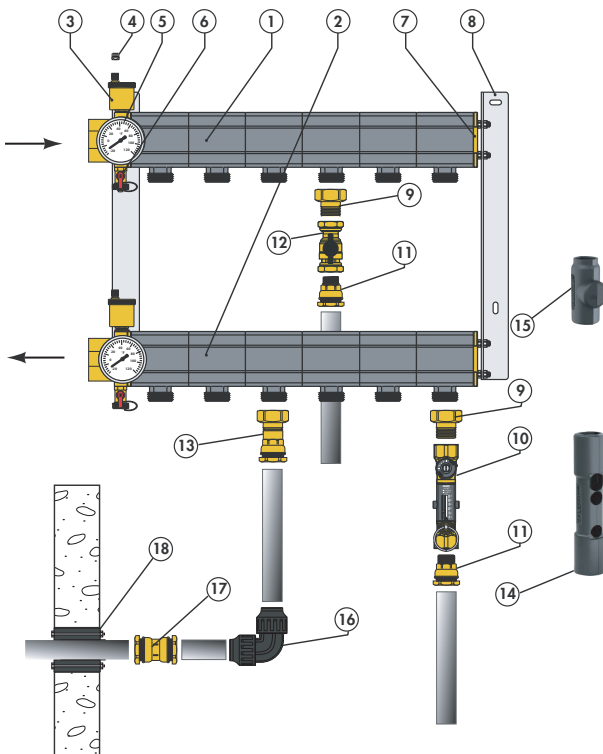

1. Supply manifold
 2. Return manifold
 3. Air vent
 4. Vent cap adapter NA10204 (for methanol/ethanol fluids)
 5. Temperature gage
 6. Drain valve
 7. Blind end plug
 8. Bracket
 9. Manifold outlet fitting 110050A/60A*
 10. QuickSetter 132552A/662A*
 11. GeoGrip pipe coupling 861527A/634A*
 12. Isolation valve NA39589/NA39753*
 13. GeoGrip manifold to earthloop pipe connector NA10246/247*
 14. Optional insulation shells for QuickSetters with inlet/outlet fittings 112001/003*
 15. Optional insulation shells for isolation valves with inlet/outlet fittings 111001/003*
 16. GeoGrip elbow NA866027/034*
 17. GeoGrip sleeve coupling 863027/034*
 18. GeoSeal Wall penetration seal NA10248/NA10249*
- * Part numbers for 3/4" / 1" sizes

Flexible pipe connection choices:

- A. Connect directly to earthloop piping using item 13.
- B. Connect using isolation valves with items 9,11,12.
- C. Connect using QuickSetters with items 9,10,11.

Construction details

The manifold modules have been designed to prevent condensation. Polymer construction with an air gap insulating the medium from outside humidity reduces the effects of exterior corrosion.

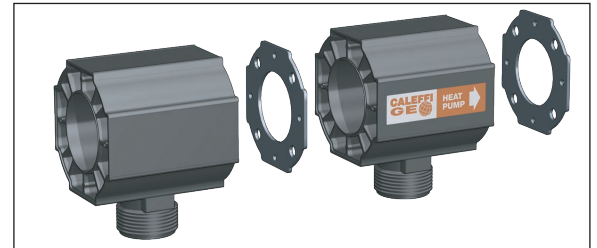

The manifold is reversible providing installation flexibility for easy connection to the earthloops with respect to the heat pump.

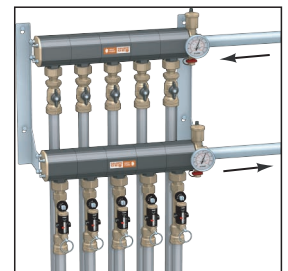
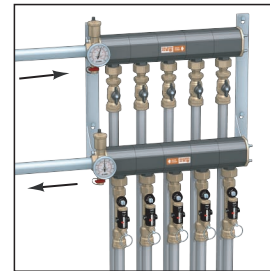

Two brass end caps and four tie-rods compress the modules to ensure proper sealing. The seal between the modules isolates the internal fluid duct and the single air chambers.

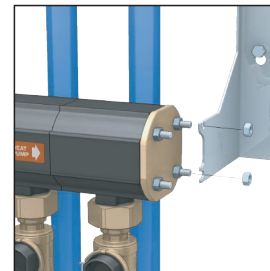
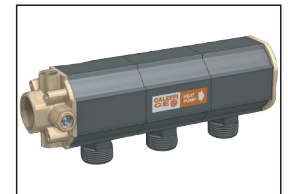

The bracket can be mounted to a wall before mounting the manifold to allow for easy connection to the earthloops.

GeoGrip™ and GeoSeal™ fittings for pipe in main heat pump circuit supply and return lines

Inside mechanical room installation

To isolate the manifold and connect directly to the heat pump with metal pipe, use ball valve (1) with double nipple (2) on both heat pump circuit supply and return ports. The QuickSetter balancing valve with flowmeter (3) can replace the ball valve on the supply line combining isolation valve and flow setting. In addition, the QuickSetter (3) provides a way to measure the total ground heat exchanger flowrate which, along with supply and return temperatures read from the manifold temperature gages, can be used to calculate the heat supplied by the earthloop system.

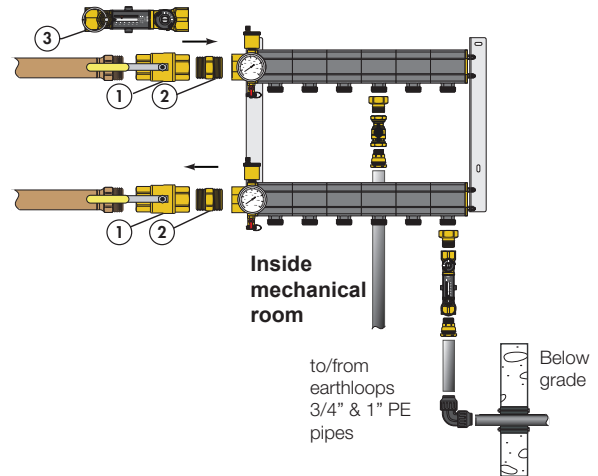

Outside buried vault installation

To isolate the manifold and connect to the heat pump with buried PE pipe, use ball valve (4) with double nipped (2) on the heat pump circuit supply and return ports. Alternatively, brass ball valve (1) can be installed with double nipple (2) and male adapter (5) to connect to PE pipe. Additional GeoGrip fittings are available to complete the piping layout to the heat pump in the mechanical room: elbow coupler (6), sleeve coupler (7), and GeoSeal wall penetration seal (8). See previous page for 3/4" and 1" GeoGrip and GeoSeal fittings for the earthloop circuits. The QuickSetter balancing valve with flowmeter (3) can replace the ball valve on the supply line combining isolation valve and flow setting and calculating the heat supplied by the earthloop system.

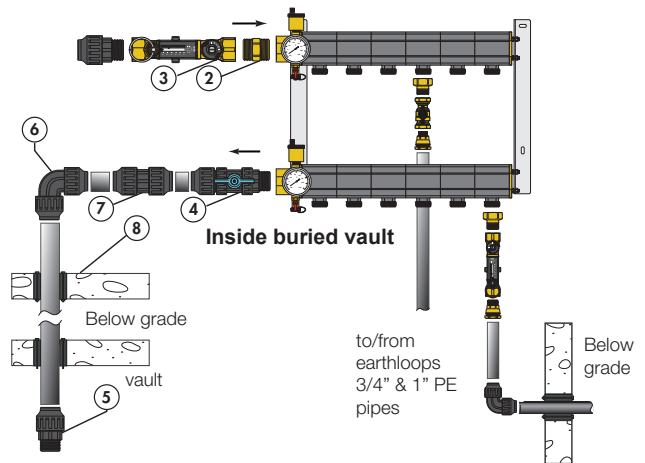

GeoGrip™ and GeoSeal™ fittings for 1-1/4" pipe in heat pump circuit main supply and return lines

GeoGrip mechanical fittings for connecting HDPE geothermal piping. The GeoSeal wall penetration seal is ideal for connecting ground earthloop systems to heat pumps through concrete walls.

Product range

Code NA39588	Ball valve with lever, 1-1/4" NPT female brass	①
Code NA10263	Double nipple, 1-1/4" NPT brass	②
Code 132772A	QuickSetter balancing valve with flowmeter, 1-1/4" NPT female brass	③
Code 132882A	QuickSetter balancing valve with flowmeter, 1-1/2" NPT female brass	
Code NA10268	GeoGrip ball valve with T-handle, 1-1/4" NPT male x PE pipe compression	④
Code NA10269	GeoGrip male adapter, 1-1/4" NPT x PE pipe compression	⑤
Code NA866042	GeoGrip elbow coupling, 1-1/4" x 1-1/4" PE pipe compression	⑥
Code NA863042	GeoGrip pipe sleeve coupling, 1-1/4" x 1-1/4" PE pipe compression	⑦
Code NA10265	GeoSeal 1-1/4" wall penetration seal	⑧

Technical specification

For all GeoGrip fittings items 4-7:

Body and lock nut:	Polypropylene
O-ring:	EPDM
Clenching ring:	Polyacetal resin
Suitable fluids:	water, 50% max. glycol solutions, 25% max. methanol solutions, 30% max. ethanol solutions, saline solutions
Max. working pressure:	230 psi (16 bar)
Max. working temperature:	140°F (60°C)



QuickSetter™ Balancing valve with flow meter series 132



Function

QuickSetter balancing valves allow setting the flow rate in earthloop circuits without requiring calibration equipment. Flow adjustment is performed with the system running using a simple 3 step process: 1) pull by-pass circuit pin; 2) while viewing site gage, turn stem to adjust flow to desired value; 3) release by-pass circuit pin. Flow gage is hermetically sealed from flow stream thus preventing scaling and clouding of glass. By-pass circuit prevents debris from affecting flow accuracy. To facilitate circuit purging and filling, the QuickSetter also serves as an isolation valve when adjustment stem is fully turned clockwise.

Product range

Code 132552A	2.0 - 7.0 GPM	3/4" NPT
Code 132662A	3.0 - 10.0 GPM	1" NPT

Technical specification

Valve & flowmeter body, and ball	brass
Ball control stem & bypass valve stem:	brass, chrome-plated
Ball seal seat:	PTFE
Control stem guide & flowmeter float & indicator cover:	PSU
Flowmeter springs:	stainless steel
Seals:	EPDM
Suitable fluids: water, 50% max. glycol solutions, 25% max. methanol solutions, 30% max. ethanol solutions, saline solutions	
Max. working pressure:	150 psi (10 bar)
Max. temperature:	230°F(110°C)
Accuracy:	±10%
Flow rate correction factor for 20%-30% glycol solutions:	0.9

Code 132772A	5.0 - 19.0 GPM	1 1/4" NPT
Code 132882A	8.0 - 32.0 GPM	1 1/2" NPT

Isolation shutoff ball valves series NA39



Function

These full port ball valves with blow-out proof stem are used with the GeoCal manifold to isolate geothermal earthloop circuits for purging and filling. If a circuit becomes unusable for any reason, it can be shut off and isolated from the rest of the system,

Product range

Code NA39589	Ball valve with T-handle, 3/4" NPT female
Code NA39753	Ball valve with T-handle, 1" NPT female
Code NA39588	Ball valve with lever, 1-1/4" NPT female

Technical specification

Valve body:	brass
Ball:	brass, chrome-plated
Seats, seals and thrust washer:	PTFE
Suitable fluids: water, 50% max. glycol solutions, 25% max. methanol solutions, 30% max. ethanol solutions, saline solutions	
Max. working pressure:	150 psi (10 bar)
Max. temperature:	365°F (185°C)



GeoGrip™ and GeoSeal™ fittings for HDPE pipe

Function

GeoGrip mechanical fittings with o-ring seals are high quality compression-style fittings used for connecting HDPE geothermal piping. The GeoSeal wall penetration seal forms a water-tight mechanical seal between the pipe and the hole it passes through, ideal for connecting ground earthloop systems to heat pumps through concrete walls.

Product range

Code 110050A	3/4" NPT male to GeoCal manifold	9
Code 110060A	1" NPT male to GeoCal manifold	9
Code 861527A	GeoGrip 3/4" HDPE pipe x 3/4" NPT male	11
Code 861634A	GeoGrip 1" HDPE pipe x 1" NPT male	11
Code NA10246	GeoGrip 3/4" HDPE pipe to GeoCal manifold	13
Code NA10247	GeoGrip 1" HDPE pipe to GeoCal manifold	13
Code NA866027	GeoGrip 3/4" x 3/4" HDPE pipe elbow coupling	16
Code NA866034	GeoGrip 1" x 1" HDPE pipe elbow coupling	16
Code 863027	GeoGrip 3/4" x 3/4" HDPE pipe sleeve coupling	17
Code 863034	GeoGrip 1" x 1" HDPE pipe sleeve coupling	17
Code NA10248	3/4" wall penetration seal	18
Code NA10249	1" wall penetration seal	18

Technical specification

GeoGrip fittings except 90° elbow:	
Body and lock nut:	brass
Seal:	NBR
NA866027 and NA866034 90° elbow:	
Body and lock nut:	Polypropylene
O-ring:	EPDM
Clenching ring:	Polyacetal resin
Suitable fluids: water, 50% max. glycol solutions, 25% max. methanol solutions, 30% max. ethanol solutions, saline solutions	
Max. working pressure:	230 psi (16 bar)
Max. working temperature:	140°F (60°C)

