

DC-EMC solar pump

NA26711



(Shown with two 3/4" sweat unions)
(not included, see page 2)

Application

The DC-ECM solar pump can be used for most circulation pump applications without connection to the power grid. Highly efficient, the DC-ECM solar pump can be connected directly to a photovoltaic panel and is characterized by its small size, high efficiency, and extremely low power consumption. The shaftless spherical motor technology provides maintenance free and provides quiet service and maintenance free life.

This pump is ideal for single family home thermal solar systems or any circulation pump application where conventional power is not available.

Product range

Code: NA26711 DC-ECM solar pump operates on 8 to 25 VDC.....1" male union thread

Technical specification

Materials

Pump body: brass
 Bearing: ceramic ball
 Seals: EPDM
 Impeller: wet rotor
 Motor: permanent magnet ECM

Performance

Voltage: 8 - 25 VDC
 Power consumption: 3 - 55W
 Current draw: 0.13 - 2.1 A
 Insulation class: IP 42 / Class F
 Suitable fluids: water, glycol solution
 Max percentage of glycol: 50%
 Max. working pressure: 150 PSI (10 bar)
 Max. temperature: -10° F to 230° F (-10 to 110°C)
 Flow rates:
 12V up to 5 gpm (19 lpm)
 24V up to 7 gpm (26.5 lpm)
 Pump head:
 12V up to 10 ft (3.0 m)
 24V up to 15 ft (4.6 m)

Connections: 1" male union half threads
 Face to face dimension: 5 1/8"(130 mm)

Dimensions

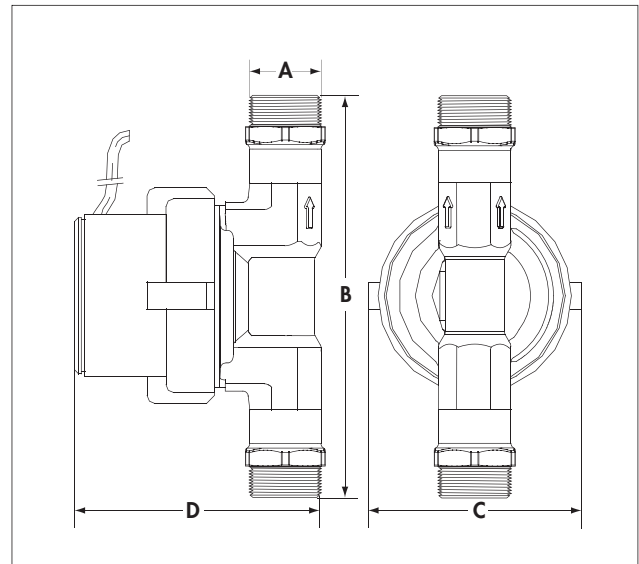

Code	A	B	C	D	Weight (lb)
NA26711	1"	5 1/8"	3 1/8"	3 1/4"	3.0

Hydraulic characteristics

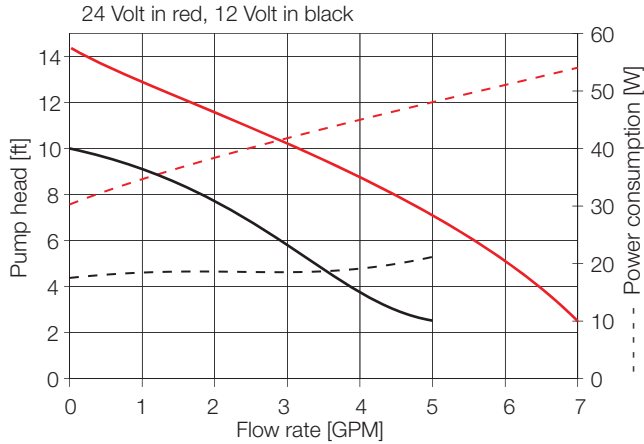

Operating principle

The single moving part in a spherical motor is a hemispherical rotor/impeller unit. The rotor/impeller rides on an ultra-hard, wear-resistant ceramic sphere. There are no conventional shaft bearings or seals. This eliminates the possibility of bearing-play which is commonly associated with increased noise and the seal-less design eliminates a potential leak path. These pumps are particularly robust and provide an exceptionally long service life in excess of 50,000 hours. The self-aligning bearing is lubricated and cooled by the fluid media. Maintenance is not necessary under normal conditions. Even after lengthy shutdown periods a reliable start-up is virtually guaranteed. Parts exposed to the fluid are completely corrosion resistant even with aggressive fluids.

Construction design

The pump housing brass is for use in both solar systems and potable water. The pump motor is fixed to the pump housing by the screw ring, which enables easy removing and disassembly. The motor has electronic integrated thermal overload protection, interference suppressor and integrated reverse polarity protection. Power cord double-wire is red/black for polarity. The pump motor and the integrated electronic parts are moisture resistant.

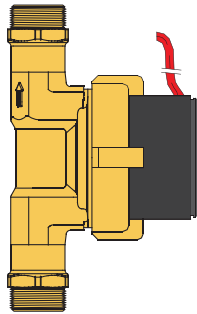

Integrated overtemperature protection

The pump comes with an integrated overtemperature safety device, which shuts the pump electronics off when reaching overtemperature. A complete shutdown after reaching an overtemperature condition can result in adverse effects on the solar system. Since the temperature of the electronic components is influenced by the temperature of the pumped media, the pump will lower its speed automatically after reaching a critical temperature level in order to avoid a total system shutdown. However, if the temperature continues to rise because of too hot of pumped media, the pump will eventually shut down completely. After cooling down, the pump will restart automatically.

Installation

The pump can be fitted either vertically or horizontally, with the motor in any position, except the motor up.

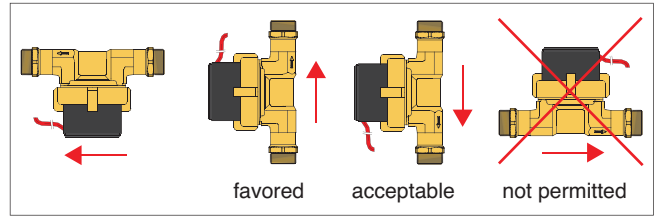

Electrical connection

Important note: Electrical installations may only be performed by a properly licensed electrician observing all applicable general and local codes.

- Connect to a 8-25 V co-current flow power supply, the red wire has to be connected with positive terminal, the black wire has to be connected with the negative terminal.
- If the system is not filled with water yet, reduce the time of a function test to an absolute minimum. Extended dry operation of the pump will damage the bearing.

Before startup

Flush the system to remove dirt, make sure the system is filled and the air has been purged. The pump can be switched on. If you hear air noises initially, these should stop after a short time. Power cycling the pump several times accelerates the air removal. If the air noise does not disappear or at least decrease substantially, repurge the system. Avoid dry run in any case, this will damage the pump.

Startup

- The starting current is much higher than the operating current for a very short time until the pump is running.
- If the voltage drops because of the high starting current, the pump will startup.

Pump station installation



The DC-ECM solar pump is a direct fit into the 255 and 256 series solar pump stations. The DC pump face to face dimensions and the male union thread are exactly the same 120V version. Simply select the 255 or 256 solar pump station configured without the pump. To install, remove the pump space pipe and mount the DC-ECM directly with the union half nuts. The iSolar 12V and 24 VDC controllers will fit into the front insulation cover of the 255 and 256 series pump station.

In-line sweat fittings

Item	Code	Description
	255056A	Dual-line solar station without pump
	256056A	Single-line solar station without pump
	NA10002	1/2" sweat tail piece, use nut and washer
	NA10003	3/4" sweat tail piece, use nut and washer
	R50055	Sealing washer, use with nut and tail piece
	R61008	Union nut 1" thread, use washer, tail piece
	59834A	1" sweat tail piece with nut, use washer