

Hydro Separator

548 Series With Union Connections

Submission Data 02909 NA - Issue Date 01/2010



Application

The hydronic separator creates a zone with a low pressure loss, which enables the primary and secondary circuits connected to it to be hydraulically independent of each other; the flow in one circuit does not create a flow in the other.

Typical Specification

Furnish and install on the plans and described herein, a Caleffi Hydro Separator as manufactured by Caleffi. Each separator must be designed with an epoxy resin painted steel body, a chrome plated brass blowdown drain valve with hose connection and automatic brass air vent. The separator design must include sweat or NPT union fittings. Each separator shall be Caleffi model NA548 or approved equal. (See product instructions for specific installation information.)

Dimensions

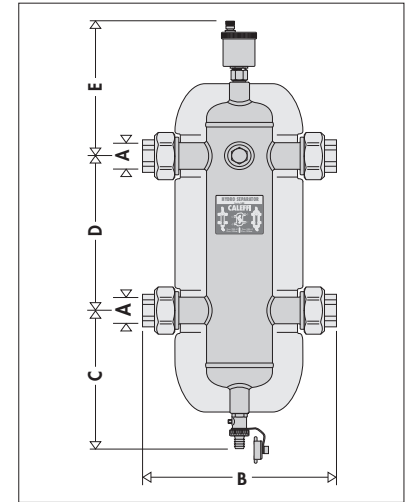

Technical Data

Threaded and sweat union connections

Materials:

- Body: epoxy resin painted steel
- Drain and shut-off valve: brass
- Air vent body: brass

Suitable fluids: water, or 50% max. glycol solution

Max working pressure: 150 psi (10 bar)

Temperature range:

- with insulation: 32-210°F (0-100°C)
- without insulation: 32-250°F (0-120°C)

Connections:

- Main: 1" & 1 1/4" sweat & NPT and 1 1/2" & 2" NPT union
- Drain: 3/4" hose
- Thermometer pocket: 1/2"

Insulation:

- Material: double density closed cell expanded PEX
- Thickness: 3/4" (20 mm)
- Density:
 - internal part: 2 lb/ft (30 kg/m³)
 - external part: 3 lb/ft (50 kg/m³)
- Thermal conductivity: 32°F (0°C): 9 BTU/in (0.038 W/m·K)
-40°F (-40°C): 11 BTU/in (0.045 W/m·K)
- Coefficient of resistance to the diffusion of vapor: > 1.300
- Temperature range: 32-210°F (0 -100°C)
- Reaction to fire (DIN 4102) : class B 2

Code	A	B	C	D	E
548006A/96A	1"	8 3/4"	6 1/4"	8 5/8"	8"
548007A/97A	1 1/4"	9 3/8"	7 3/8"	9 1/2"	8 3/8"
548008A	1 1/12"	10 7/8"	7 3/4"	10 1/4"	8 3/4"
548009A	2"	12"	10 1/8"	11 7/8"	9 1/2"

Code	Weight (lb)	(kg)	Flow (gpm)	(l/sec)	Volume (gal)	(l)
548006A/96A	7.5	3.4	11.0	0.7	0.5	1.9
548007A/97A	8.3	3.8	18.0	1.1	0.7	2.6
548008A	12.5	5.7	26.0	1.6	1.3	4.9
548009A	26.0	11.8	37.0	2.3	3.5	13.2

Note: 96A and 97A have sweat unions, all others have NPT unions.

Hydraulic characteristics

The hydronic separator should be sized according to the maximum flow rate at the inlet. The selected design value must be the greatest between the primary circuit and the secondary circuit.

Size	Flow Capacity			
	1"	1 1/4"	1 1/2"	2"
gpm	11.0	18.0	26.0	37.0
l/sec.	0.7	1.1	1.6	2.3

We reserve the right to change our products and their relevant technical data, contained in this publication, at any time and without prior notice. Contractors should request production drawings if prefabricating the system.

Job name _____
 Job location _____
 Engineer _____
 Mechanical contractor _____
 Contractor's P.O. No. _____
 Representative _____

Size _____
 Quantity _____
 Approval _____
 Service _____
 Tag No. _____
 Notes _____