

DISCALDIRT® - Air & Dirt Separator

NA546 ASME & CRN Series, Steel: 8, 10 and 12 inch

Submittal Data 02920.1 NA — Issue Date 04/2011



Application

Air and dirt separators are used to continuously remove air and debris contained in the hydronic circuits of heating and cooling systems. The air discharge of these devices is very high. They are capable of automatically removing all of the air present in the system down to the micro-bubble level. The DISCALDIRT® air and dirt separator also separates any solid impurities in the system. The impurities collect at the bottom of the device and can be removed through the drain pipe, to which a separately sourced drain valve can be mounted. The circulation of fully de-aerated and cleaned water enables the equipment to operate under optimum conditions, free from noise, corrosion, localized or mechanical damage.

Typical Specification

Furnish and install on the plans and described herein, a Caleffi DISCALDIRT air and dirt separator as manufactured by Caleffi. Each separator must be designed with a side drain valve and automatic air vent. The separator design must include a large internal volume, and a stainless steel internal screen to automatically remove all dirt present in the system with particle separating capacity to 5µm (0.2 mil). The separator must be constructed in accordance with the latest revision of the ASME Boiler and Pressure Vessel Code and stamped for 150 psi (10 bar) working pressure. Each separator shall be Caleffi model NA546 or approved equal. (See product instructions for specific installation information.)

Technical specifications

- Materials:
- Body: epoxy resin painted steel
 - Internal element: stainless steel
 - Automatic air vent body: brass
 - Seals: EPDM
- Suitable fluids: water, with up to a 50% glycol solution
- Max working pressure: 150 psi (10 bar)
- Temperature range: 32–250°F (0–120°C)
- Connections:
- Flanged: (ASME & CRN Registered) 8" – 12" ANSI B16.5 Class 150 RF
 - Drain Pipe: 2" NPT male

Hydraulic characteristics

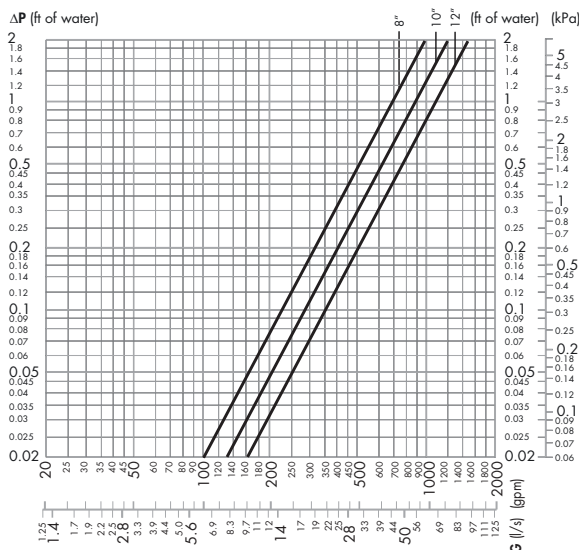

Dimensions

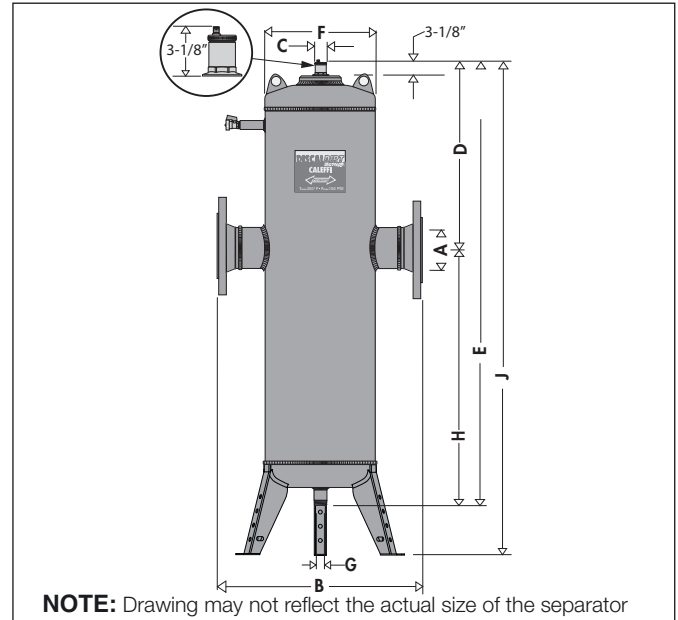

Code	A	B	C	D	E	F	G	H	J	Cap. (gal)	Cap. (liters)	Weight (lb)	Weight (Kg)
NA546 200A	8"	35 7/16"	2 3/16"	35 9/16"	75 3/8"	20"	2"	43 5/16"	92 3/4"	95	360	355	249.5
NA546 250A	10"	41 3/4"	2 3/16"	38 9/16"	83 11/16"	26"	2"	48 1/4"	101 1/16"	175	662	555	329.0
NA546 300A	12"	46 7/16"	2 3/16"	41 1/8"	90 9/16"	30"	2"	52 9/16"	107 5/16"	255	965	825	498.9

Flow capacity

The fluid velocity at connections for DISCALDIRT 546 series air and dirt separators is recommended to not exceed 10.0 f/s. Above this speed, heavy internal turbulence and noise can occur and air and dirt elimination efficiency begins to fall measurably. Optimal air and dirt elimination performance occurs at fluid velocities of 4.0 f/s or less. See the flow capacity chart.

		FLOW CAPACITY			
		Size	8"	10"	12"
Optimal (≤4.0 f/s)	GPM	625	980	1,410	
	l/s	40.0	62.0	89.0	
Max. (10.0 f/s)	GPM	1,570	2,450	3,530	
	l/s	100	155	222	
Cv		1,109	1,387	1,664	

We reserve the right to change our products and their relevant technical data, contained in this publication, at any time and without prior notice. Contractors should request production drawings if prefabricating the system.

Job name _____
 Job location _____
 Engineer _____
 Mechanical contractor _____
 Contractor's P.O. No. _____
 Representative _____

Size _____
 Quantity _____
 Approval _____
 Service _____
 Tag No. _____
 Notes _____