

DISCALDIRT® Air & Dirt Separator

546 Series, Steel

Submittal Data 02921 — Issue Date 04/2011



Application

Air and dirt separators are used to continuously remove air and debris contained in the hydronic circuits of heating and cooling systems. The air discharge of these devices is very high. They are capable of automatically removing all of the air present in the system down to the micro-bubble level. The DISCALDIRT® air and dirt separator also separates any solid impurities in the system. The impurities collect at the bottom of the device and can be removed through the drain pipe, to which a separately sourced drain valve can be mounted. The circulation of fully de-aerated and cleaned water enables the equipment to operate under optimum conditions, free from noise, corrosion, localized or mechanical damage.

Typical Specification

Furnish and install on the plans and described herein, a Caleffi DISCALDIRT air and dirt separator as manufactured by Caleffi. Each separator must be designed with a side drain valve and automatic air vent. The separator design must include a large internal volume, and a stainless steel internal screen to automatically remove all dirt present in the system with particle separating capacity to 5µm (0.2 mil). The separator must be constructed in accordance with the latest revision of the ASME Boiler and Pressure Vessel Code and stamped for 150 psi (10 bar) working pressure. Each separator shall be Caleffi model 546 or approved equal. (See product instructions for specific installation information.)

Technical Data

- Materials:
- Body: epoxy resin painted steel
 - Internal screen: stainless steel
 - Automatic air vent body: brass
 - Seals: EPDM
- Suitable fluids: water, with up to a 50% glycol solution
- Max working pressure: 150 psi (10 bar)
- Temperature range: 32–250°F (0–120°C)
- Connections:
- Flanged: 2" – 6" ANSI B16.5 Class 150 RF
 - Drain pipe: 1" NPT male

Hydraulic characteristics

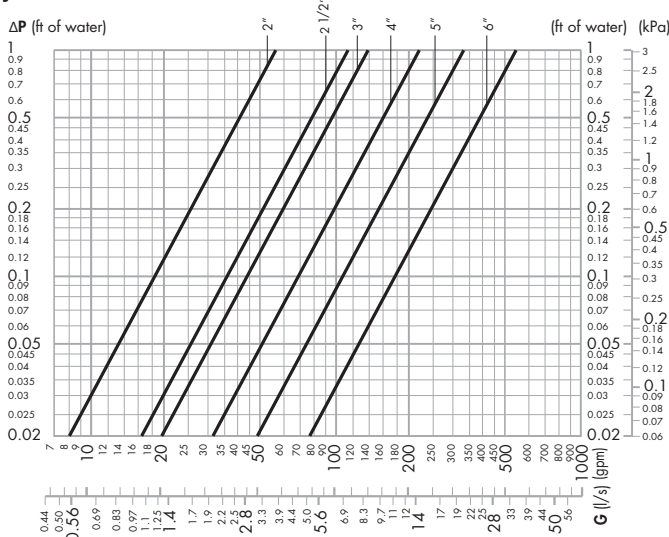

Dimensions

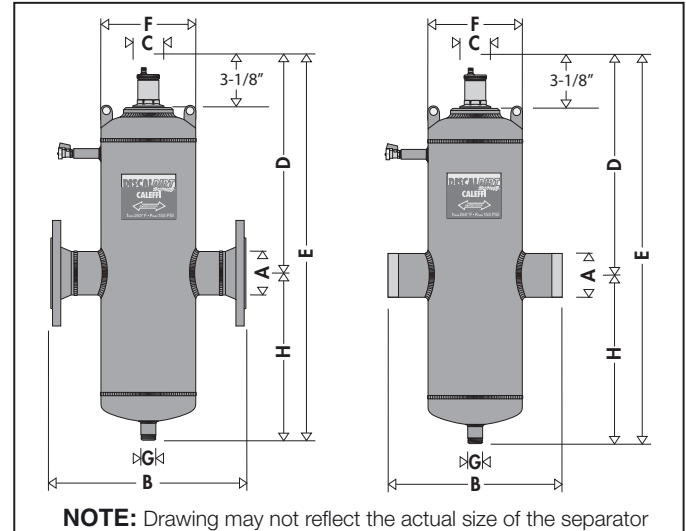

Code	A	B	C	D	E	F	G	H	Cap. (gal)	Cap. (liters)	Weight (lb)	Weight (Kg)
546050A	2"	13 3/4"	2 3/16"	14 3/4"	28 1/4"	6 5/8"	1"	12 1/2"	3.6	13.6	39.7	18.0
546060A	2 1/2"	13 3/4"	2 3/16"	14 3/4"	28 1/4"	6 5/8"	1"	12 1/2"	3.6	13.6	41.9	19.0
546080A	3"	18 3/8"	2 3/16"	17 1/8"	34 1/2"	8 5/8"	1"	16 5/16"	7.6	28.8	72.7	33.1
546100A	4"	18 1/2"	2 3/16"	17 1/8"	34 1/2"	8 5/8"	1"	16 5/16"	7.8	29.5	77.1	35.0
546120A	5"	25"	2 3/16"	21 5/16"	46 11/16"	12 3/4"	1"	24 5/8"	22.4	84.8	180.7	82.0
546150A	6"	25"	2 3/16"	21 5/16"	46 11/16"	12 3/4"	1"	24 7/16"	23	87.0	187.3	85.0

Flow capacity

The fluid velocity at connections for DISCALDIRT 546 series air and dirt separators is recommended to not exceed 10.0 f/s. Above this speed, heavy internal turbulence and noise can occur and air and dirt elimination efficiency begins to fall measurably. Optimal air and dirt elimination performance occurs at fluid velocities of 4.0 f/s or less. See the flow capacity chart.

		FLOW CAPACITY						
		Size	2"	2 1/2"	3"	4"	5"	6"
Optimal (≤4.0 f/s)	GPM	37.3	63.0	95	149	259	380	
	l/s	2.4	4.0	6.0	9.4	16.3	24.0	
Max. (10.0 f/s)	GPM	88.8	150.1	227.4	355.3	616.4	903.6	
	l/s	5.6	9.5	14.3	22.4	38.9	57.0	
	Cv	87	174	208	324	520	832	

We reserve the right to change our products and their relevant technical data, contained in this publication, at any time and without prior notice. Contractors should request production drawings if prefabricating the system.

Job name _____

Job location _____

Engineer _____

Mechanical contractor _____

Contractor's P.O. No. _____

Representative _____

Size _____

Quantity _____

Approval _____

Service _____

Tag No. _____

Notes _____