

FLOWCAL™ automatic flow balancing valve with polymer cartridge

121 Series

Submittal Data 02935 NA — Issue Date 08/2011



Application

The FlowCal™ automatic flow balancing valve maintains a constant fixed flow rate within varying system differential pressure ranges. Operation is fully automatic requiring no manual adjustment. The 121 series utilize an exclusive, interchangeable flow cartridge, made of anti-scale, low noise polymer for use in cooling and heating systems. The FlowCal 121 series automatic flow balancing valves are available with integral shut-off ball valve and optional factory-installed pressure and temperature test ports. Drain valves are also available as an accessory for installing in the blowdown port connection.

Typical Specification

Furnish and install on the plans and describing herein, a Caleffi FLOWCAL™ automatic flow balancing valve and integral ball valve as manufactured by Caleffi. Brass body. Each balancing valve must be designed with a Y-style brass body NPT female or sweat with union by NPT female or sweat end connections, with brass pressure and temperature test port plugs. The balancing valve design must include an anti-scale polymer flow cartridge, stainless steel spring and EPDM seals. The integral ball valve must include a chrome-plated brass ball, PTFE ball seat and stem seal, and a zinc-plated steel lever with vinyl grip. Each valve must be designed for fixed flow rates ranging from 1/2 - 21 gpm with ±10% accuracy, 400 psi (400 WOG) maximum working pressure and working temperature range of 32 - 212°F (0 -100°C).

(See product instructions for specific installation information.)

Technical Data

Valve Materials:

- Body: brass
- FlowCal flow cartridge: anti-scale polymer
- Spring: stainless steel
- Seals: EPDM
- Ball: brass, chrome-plated
- Ball seat and stem seal: PTFE
- Lever: zinc coated steel with vinyl grip
- Pressure and temperature test port plugs: brass
- Pressure and temperature test ports: body and cap-brass; core-nordel

- Drain port plug: brass
- Medium: water, glycol solutions
- Max. percentage of glycol: 50%
- Max. working pressure: 400 psi (400 WOG)
- Working temperature range: 32–212°F (0 –100°C)

Connections: 1/2", 3/4", 1", 1 1/4" FNPT or sweat with union x FNPT or sweat

Pressure and temperature test port connections: 1/4" FNPT

Blowdown port connection: 1/2" - 3/4": 1/4" FNPT
1" - 1 1/4": 1/2" FNPT

Flow rate: 27 flow rate settings ranging from 0.5 - 21 GPM

Flow accuracy: ±10%

Differential pressure control ranges: 2-14, 2-32, 4-34, 5-35, 3-32, 4-35

Identification: metal plate with ball chain stating ΔP range and fixed flow rate

We reserve the right to change our products and their relevant technical data, contained in this publication, at any time and without prior notice. Contractors should request production drawings if prefabricating the system.

Job name _____
 Job location _____
 Engineer _____
 Mechanical contractor _____
 Contractor's P.O. No. _____
 Representative _____

Dimensions

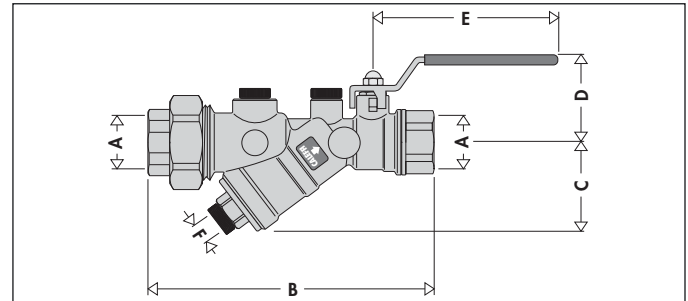

Code	A	B	C	D	E	F	Weight (lb)
121141...	1/2"	6 3/16"	1 15/16"	1 15/16"	3 15/16"	1/4"	2.7
121151...	3/4"	6 1/4"	1 15/16"	1 15/16"	3 15/16"	1/4"	2.7
121161...	1"	8 5/8"	3 3/4"	2 5/8"	4 3/4"	1/2"	5.0
121171...	1 1/4"	8 11/16"	3 3/4"	2 5/8"	4 3/4"	1/2"	5.0

GPM	Last 3 digit ●●●	Differential Control Pressure Ranges (psid)
0.5	G50	2-14
0.75	G75	
1	1G0	
1.5	1G5	
2	2G0	
2.5	2G5	2-32
3	3G0	
3.5	3G5	
4	4G0	
4.5	4G5	
5	5G0	4-34
6	6G0	
7	7G0	
8	8G0	
9	9G0	
10	10G	5-35
11	11G	
12	12G	
13	13G	
14	14G	
15	15G	3-32
16	16G	
17	17G	
18	18G	
19	19G	
20	20G	
21	21G	
		4-35

Size _____
 Quantity _____
 Approval _____
 Service _____
 Tag No. _____
 Notes _____