

VBus[®]/PWM interface adapter

Mounting

Connection

Operation



49011800

Thank you for buying this product.
Please read this manual carefully to get the best performance from this unit.
Please keep this manual carefully.

Table of contents

Safety advice	2	5. DIP switches.....	6
Information about the product.....	3	6. Commissioning	6
Technical data	3	6.1 Initialisation phase.....	7
1. Mounting.....	4	6.2. Indication of the selected relay	7
2. Connection.....	4	6.3 Error message.....	7
3. Adjusting the signal type	5	Imprint	8
4. Addressing the signal output	5		

Safety advice

Please pay attention to the following safety advice in order to avoid danger and damage to people and property.

This manual contains important information about safe and proper usage of this product. Please keep this manual for future reference.

Instructions

Attention must be paid to the valid local standards, regulations and directives!

Subject to technical change. Errors excepted.

Description of symbols

WARNING!	<p>Warnings are indicated with a warning triangle! → They contain information on how to avoid the danger described.</p>

Signal words describe the danger that may occur, when it is not avoided.

Warning means that injury, possibly life-threatening injury, can occur.

Attention means that damage to the appliance can occur.



Note

Notes are indicated with an information symbol.

→ Arrows indicate instruction steps that should be carried out.

Information about the product

Proper usage

The VBus®/PWM interface adapter may only be used for the speed control of a pump in combination with an electronic controller for solar thermal systems via the VBus® in compliance with the technical data specified in these instructions. Improper use excludes all liability claims.



Note

Strong electromagnetic fields can impair the function of the device.

→ Make sure the device is not exposed to strong electromagnetic fields.

Disposal

- Dispose of the packaging in an environmentally sound manner.
- Dispose of old appliances in an environmentally sound manner. Upon request we will take back your old appliances bought from us and guarantee an environmentally sound disposal of the devices.

CE-Declaration of conformity

The product complies with the relevant directives and is therefore labelled with the CE mark. The Declaration of Conformity is available upon request, please contact the manufacturer.



VBus®/PWM interface adapter

Overview



- **Speed control of high-efficiency pumps for controllers without integrated PWM outputs**
- **Easy to install**
- **Convertible from PWM to 0-10 V signal**
- **With 7-segment LED display**

VBus®/PWM interface adapter

The VBus®/PWM interface adapter is used for the speed control of a pump via a PWM or 0-10 V signal. Via the VBus® the adapter receives information from the controller about speed. The speed is converted into a PWM or direct voltage signal and put out to the corresponding terminals.

A signal corresponding to the speed is only available if the corresponding relay is designed for pump speed control. Otherwise, a signal – depending on the position of the relay – for the on or off state is transmitted.

The VBus®/PWM interface adapter is designed for the connection to the following devices: Caleffi iSolar series

Technical data

Housing: plastic

Protection type: IP 20 (EN 60529)

Ambient temperature: 0 ... 70 °C

Dimensions: 95 × 70 × 25 mm

Mounting: Wall mounting is possible (but not required)

Display: 7-segment LED display

Power supply:

Mains power supply:

220 ... 240 V~ / 50-60 Hz

Adapter: power supply:

12 VDC, 0.5 A

5.5 × 2.5 mm 

Interface: VBus®

Included:

1 × mains adapter 12 V / 0.5 A / 5.5 × 2.5 mm

1 × VBus® cable 1.5 m

1 × accessory bag containing

2 × screw and wall plug

4 × self-adhesive, skid-proof rubber pad

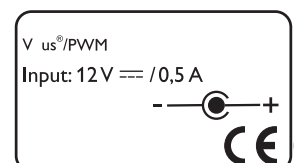

1. Mounting

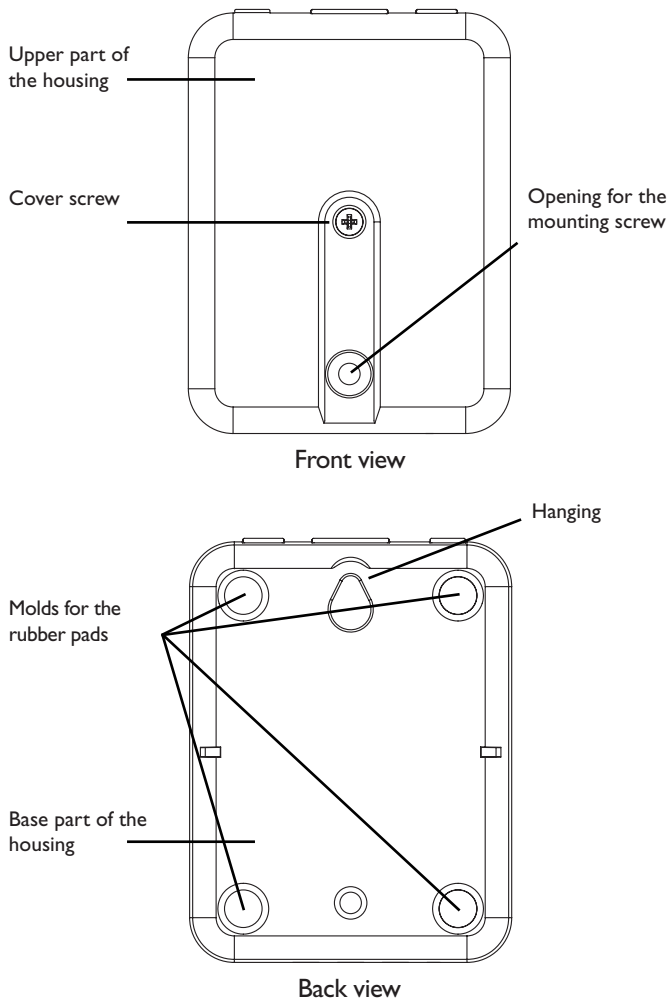

ATTENTION!	ESD damage! Electrostatic discharge can lead to damage to electronic components! → Take care to discharge properly before touching the inside of the device. To do so, touch a grounded surface such as a radiator or tap!

The unit must only be located in dry interior locations. It is not suitable for installation in hazardous locations. Please pay attention to separate routing of sensor cables and mains cables.

The interface adapter is light and small enough to not require any form of mounting. It can be placed on a suitable surface (pay attention to the ambient temperature!).

Four self-adhesive, skid-proof rubber pads are included with the adapter. If necessary, these can be affixed to the corresponding molds on the base part of the housing to ensure a secure placement of the device without wall mounting.

If desired, the interface adapter can be mounted to a wall:

- Mark the desired hanging position on the wall
- Drill and prepare the hole with a wall plug and screw
- Hang the device onto the screw
- Mark the position for the mounting screw (distance to hanging point centre: 70 mm)
- Drill and prepare a hole with a wall plug
- Hang the device and fasten it by means of the second screw

For wall mounting, opening the housing is not required. Opening the housing is only required for access to the terminals.

- To open the housing, unscrew the cover screw and pull off the upper part of the housing
- To close the housing again, relocate the upper part of the housing and refasten the cover screw

Connection scheme

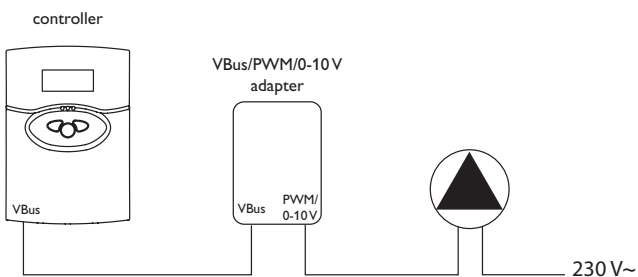

Adjustments to be made in the controller

If a VBus®/PWM interface adapter is to be used for pump speed control, the pump speed control option of the controller must not be changed or deactivated!



Note

An external mains connection to the pump must be made (see figure to the left).

2. Connection

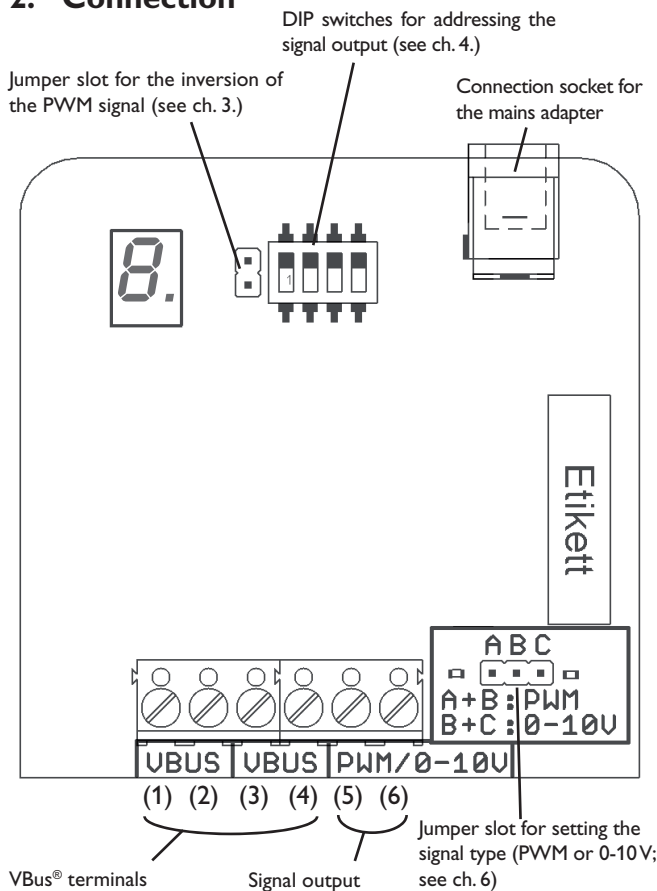

	ATTENTION!
	Short circuit! A short circuit can lead to damage to electronic components! → Finish terminal connection and close the housing before establishing the mains connection!

The interface adapter comes with a mains adapter for the power supply.

The pump is to be connected to the signal output at the terminals 5 and 6 (see table below).

The VBus®/PWM interface adapter comes with a pre-connected VBus® cable. The second pair of VBus® terminals can be used for the connection of another VBus® device.

VBus® connection at the terminals:	
VBus (1 + 2; 3 + 4)	= VBus® input / output, either polarity
Pump connection at the terminals:	
Signal output (5)	= PWM or 0-10V
GND (6)	=

3. Adjusting the signal type

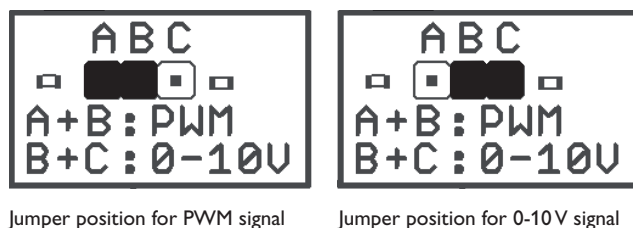

The jumper to the right of the terminals is used for determining whether a PWM signal or 0-10V signal is to be used.

The jumper poles are indicated with A, B and C.

Jumper position A+B = PWM signal (factory setting)

Jumper position B+C = 0-10V-Signal

Changing the signal type:

→ Pull the jumper out of the slot and insert it according to the desired signal type.

4. Inverting the PWM signal

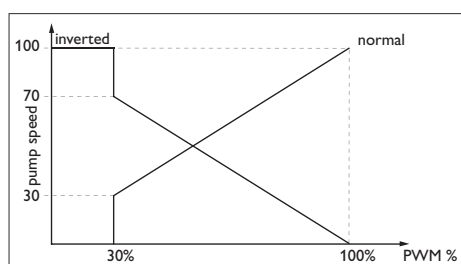
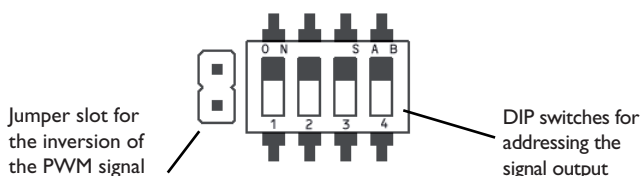

By means of the two-pole jumper slot to the left of the DIP switches, the PWM signal generated can be inverted.

Jumper **not connected:** PWM 100-0

Jumper **connected** (factory setting): PWM 0-100

Changing the factory setting:

→ To disconnect the jumper, take it off its initial position and relocate it onto only one of the pins.

The 0-10 V signal is not affected by the signal inversion.

The minimum pump speed is 30 % (see figure to the left).

Note
 Whenever the pump is switched on, it will be run at 100 % speed for a few seconds before the flexible pump speed control is effected.

5. DIP switches

The adjusted relay transmits information on pump speed which is then converted into a corresponding signal. The relay is selected by means of the DIP switches. Each relay is characterised by a certain position of the switches.

➔ put the DIP switches in the position appropriate for the desired relay.

The following table shows the position of the DIP switches for each relay,

Relay 1

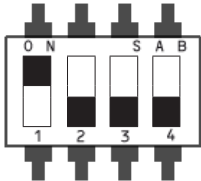

Relay 2

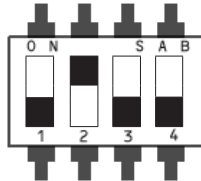

Relay 3

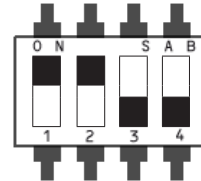

Relay 4

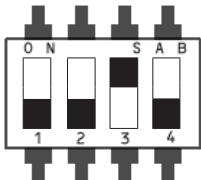

Relay 5

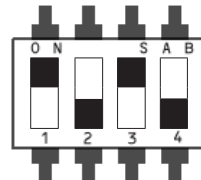

Relay 6

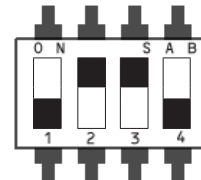

Relay 7

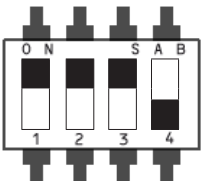

Relay 8

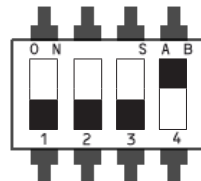

Relay 9

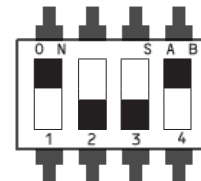

Relay 10

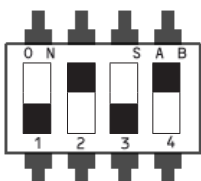

Relay 11

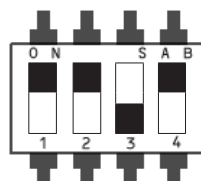

Relay 12

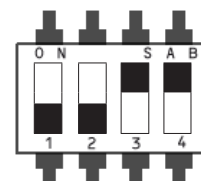

Relay 13

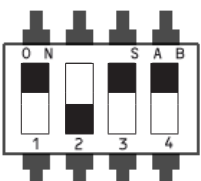

Relay 14

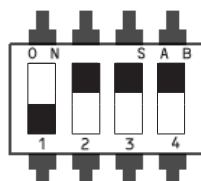

Relay 15

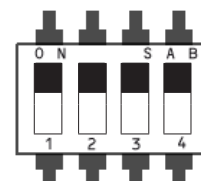

Relay 16

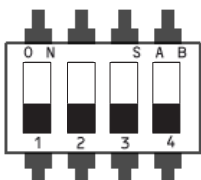

During normal operation, the relay addressed will be displayed by the 7-segment-display. See chap. 6.2.

6. Commissioning

6.1 Initialisation phase

The VBus®/PWM interface adapter is equipped with a 7-segment LED display that can indicate the selected relay or the current operational status.

When the interface adapter is connected to a controller for the first time, a short initialisation phase will be run.

During this phase, the LED display flashes first the error code *F*, then the error code *U* until the controller connected has been recognised. After a short time, the address of the selected relay will be indicated.

If the error codes do not disappear or if an *R* is indicated instead of the relay address, see chapter 6.3 for error code descriptions and troubleshooting measures.

6.2 Indication of the selected relay

The relay addressed via the DIP switches is displayed by the 7-segment-LED at the front of the adapter.

As the LED can only indicate one figure, the decimal digit is replaced with a dot when indicating relays 10 - 16:

1	= Relay 1	9	= Relay 9
2	= Relay 2	0.	= Relay 10
3	= Relay 3	1.	= Relay 11
4	= Relay 4	2.	= Relay 12
5	= Relay 5	3.	= Relay 13
6	= Relay 6	4.	= Relay 14
7	= Relay 7	5.	= Relay 15
8	= Relay 8	6.	= Relay 16

6.3 Error message

If an error occurs, the display flashes an error code:

- R* = The output addressing is faulty. The relay addressed does not exist
 - ➔ Address a valid relay
- F* = The VBus® connection is faulty
 - ➔ Check the VBus® cable
- U* = The controller connected is not recognised by the device
 - ➔ Wait for about one minute. If the error code does not disappear, contact the manufacturer

Distributed by:



CALEFFI NORTH AMERICA, Inc.

3883 W. Milwaukee Rd.

Milwaukee, WI 53208

Tel.: +1 414.238.2360

Fax: +1 414.238.2366

www.caleffi.us

sales@caleffi.com

Important notice:

We took a lot of care with the texts and drawings of this manual and to the best of our knowledge and consent. As faults can never be excluded, please note: Your own calculations and plans, under consideration of the current standards and guidelines should only be basis for your projects. We don't offer a guarantee for the completeness of the drawings and texts of this manual - they only represent some examples. They can only be used at your own risk. No liability is assumed for incorrect, incomplete or false information and / or the resulting damages.

Please note:

The design and the specifications are to be changed without notice. The illustrations may differ from the original product.

Reprinting / copying

This mounting- and operation manual including all parts is copyrighted. Another use outside the copyright requires the approval of CALEFFI NORTH AMERICA, Inc.. This especially applies for copies, translations, microfilms and the storage into electronic systems.

Editor: CALEFFI NORTH AMERICA, Inc.