

VBus[®]/USB interface adapter

Mounting

Connection

Installation



49011780

Thank you for buying this product.
Please read this manual carefully to get the best performance from this unit.
Please keep this manual carefully.

Table of contents

Safety advice	2	1. Overview	3
Description of symbols	2	2. Mounting	3
Information about the product	2	3. Connection	4
Technical data	2	4. Driver installation	4

Safety advice

Please pay attention to the following safety advice in order to avoid danger and damage to people and property.

Instructions

Attention must be paid to the valid local standards, regulations and directives!

Description of symbols

WARNING!	Warnings are indicated with a warning triangle! → They contain information on how to avoid the danger described.

Signal words describe the danger that may occur, when it is not avoided.

Warning means that injury, possibly life-threatening injury, can occur.

Attention means that damage to the appliance can occur.



Note

Notes are indicated with an information symbol.

→ Arrows indicate instruction steps that should be carried out.

Information about the product

Proper usage

The VBus®/USB interface adapter may only be used for the connection of a PC to an electronic controller for solar thermal systems via the VBus® in compliance with the technical data specified in these instructions. Improper use excludes all liability claims.

Disposal

- Dispose of the packaging in an environmentally sound manner.
- Dispose of old appliances in an environmentally sound manner. Upon request we will take back your old appliances bought from us and guarantee an environmentally sound disposal of the devices.

Target group

These instructions are exclusively addressed to authorised skilled personnel.

- Only qualified electricians should carry out electrical works.
- Initial installation must be effected by qualified personnel named by the manufacturer

Subject to technical change. Errors excepted.

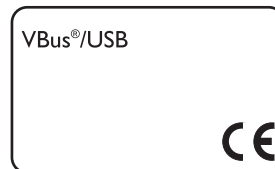

Included

- 1 × VBus®/USB interface adapter
- 1 × CD-ROM with driver RSC software
- 1 × USB – Mini-USB cable
- 1 × VBus® cable
- 1 × Accessory bag
 - 2 × Screw and wall plug
 - 4 × Self-adhesive rubber pads

System requirements

- Free USB port for adapter connection
- Microsoft Windows XP or Vista

Technical data

- Housing:** plastic
- Protection type:** IP 20 (EN 60529)
- Ambient temperature:** 0 ... 70 °C
- Dimensions:** 95 × 70 × 25 mm
- Display:** Status-LED
- Power supply:** via VBus® resp. USB
- Interface:** VBus®

CE-Declaration of conformity

The product complies with the relevant directives and is therefore labelled with the CE mark. The Declaration of Conformity is available upon request, please contact the manufacturer.



1. Overview



- for the connection of a PC with a USB port to a controller with a VBus®
- logging of measured data on the PC by means of the included RSC software
- evaluation and visualisation of system data possible with a spreadsheet software
- remote parametrisation of the controller
- no external power supply required
- USB 1.0 and 2.0 compatible

VBus®/USB interface adapter

The VBus®/USB interface adapter is the interface between the controller and a personal computer. With its standard mini-USB port it enables a fast transmission of system data for processing, visualising and archiving as well as the parametrisation of the controller via the VBus®. A full version of the ServiceCenter software is included.

The interface adapter is designed for the connection to controllers equipped with the VBus®.

2. Mounting

	<p>ATTENTION! ESD damage!</p> <p>Electrostatic discharge can lead to damage to electronic components!</p> <p>→ Take care to discharge properly before touching the inside of the device. To do so, touch a grounded surface such as a radiator or tap!</p>
--	--

The unit must only be located in dry interior locations. It is not suitable for installation in hazardous locations. The interface adapter is light and small enough to not require any form of mounting. It can be placed directly on the desk or on a system component (pay attention to the allowed ambient temperature!).

Four self-adhesive, skid-proof rubber pads are included with the adapter. If necessary, these can be affixed to the corresponding molds on the base part of the housing to ensure a secure placement of the device without wall mounting.

If desired, the interface adapter can be mounted to a wall:

- Mark the desired hanging position on the wall
- Drill and prepare the hole with a wall plug and screw
- Hang the device onto the screw
- Mark the position for the mounting screw (centres 70 mm)
- Drill and prepare a hole with a wall plug
- Hang the device and fasten it by means of the second screw

For wall mounting, opening the housing is not required. Opening the housing is only required for access to the terminals.

- To open the housing, unscrew the cover screw and pull off the upper part of the housing
- To close the housing again, relocate the upper part of the housing and refasten the cover screw

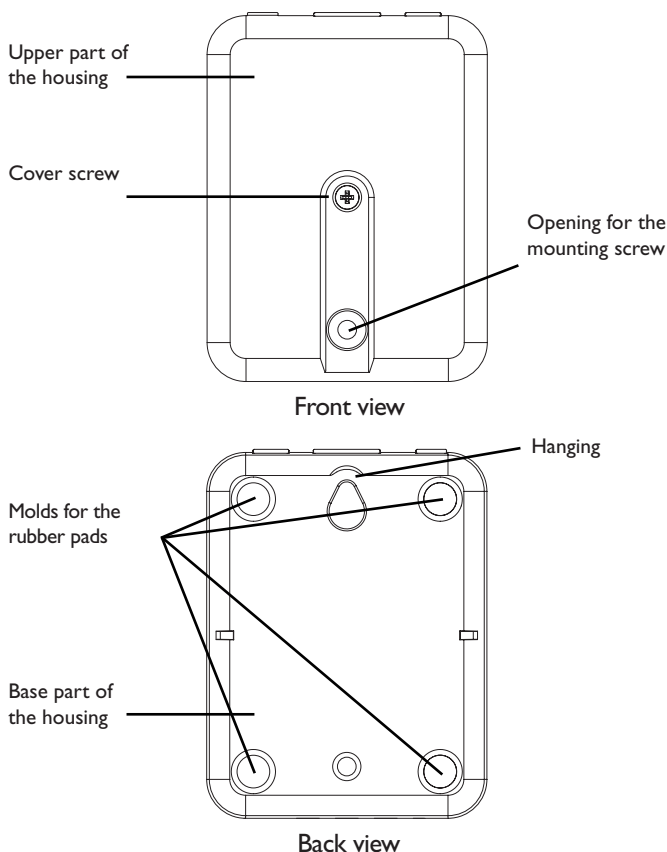

3. Connection



To connect the VBus[®] cable, proceed as follows:

- ➔ Open the housing as described in chap. 2
- ➔ Connect the included VBus[®] cable to the terminals with either polarity and route the cable as shown in the figure to the left
- ➔ Close the housing as described in chap. 2

The VBus[®] cable can be extended by or replaced with a two-wire cable (bell wire, cross section at least 0.5 mm²). The bus cable can be extended to up to 50 m in the case of a single connection. Low voltage cables must not run together in a cable conduit with cables carrying a higher voltage than 50 V!



Note

To ensure a stable USB connection, the USB cable should not be extended to more than 5 m in total.

If a cable extension is necessary, a bus cable extension is preferable to a USB cable extension.

4. Driver installation



Note

The driver software is not authorised by the Windows Logo Test. Thus, when installing the driver under Windows, a security query will appear asking for permission to continue regardless of the lacking authorisation. Answer this security query by clicking “Continue installation”.

When the VBus[®]/USB interface adapter is connected to a PC for the first time, the driver software has to be installed. All modern operating systems are equipped with an assistant software that will guide the user through the installation as soon as a new device is connected to a USB port.

The driver software required for the VBus[®]/USB interface adapter can be found on the CD-ROM included.

Distributed by:



CALEFFI NORTH AMERICA, Inc.

3883 W. Milwaukee Rd.
Milwaukee, WI 53208

Tel.: +1 414.238.2360
Fax: +1 414.238.2366

www.caleffi.us
sales@caleffi.com

Important notice:

We took a lot of care with the texts and drawings of this manual and to the best of our knowledge and consent. As faults can never be excluded, please note: Your own calculations and plans, under consideration of the current standards and guidelines should only be basis for your projects. We don't offer a guarantee for the completeness of the drawings and texts of this manual - they only represent some examples. They can only be used at your own risk. No liability is assumed for incorrect, incomplete or false information and / or the resulting damages.

Please note:

The design and the specifications are to be changed without notice. The illustrations may differ from the original product.

Reprinting / copying

This mounting- and operation manual including all parts is copyrighted. Another use outside the copyright requires the approval of CALEFFI NORTH AMERICA, Inc.. This especially applies for copies, translations, microfilms and the storage into electronic systems.

Editor: CALEFFI NORTH AMERICA, Inc.