

Hydraulic separator

548 series



cert. n° 0003
ISO 9001

01076/06 GB

Replaces 01076/05 GB



Function

This device consists of several different functional components, each of which meets specific requirements, typical of the circuits used in heating and air-conditioning systems.

- **Hydraulic separator**
To keep connected hydraulic circuits totally independent from each other.
- **Dirt remover**
To permit the separation and collection of any impurities present in the circuits. Provided with a valved connection with discharge piping.
- **Automatic air vent valve**
For automatic venting of any air contained in the circuits. Provided with a valved connection for maintenance purposes.
- **Insulation**
Flanged and welded versions of separators are supplied complete with pre-formed shell insulation to ensure perfect heat insulation when used in both hot and cold water systems.

Reference documentation

- Tech. Broch. **01031** Automatic air vent valve, 501 series
- Tech. Broch. **01054** Automatic air vent valve, 5020 series

Product range

548 series Threaded hydraulic separator with pre-formed insulation _____ sizes 1", 1 1/4", and 1 1/2" F with union
 548 series Flanged hydraulic separator with pre-formed insulation _____ sizes DN 50, DN 65, DN 80, DN 100, DN 125 and DN 150

Technical specifications

series ↔	548 threaded	548 flanged
Materials: - Separator body: - Automatic air vent body: - Automatic air vent float: - Automatic air vent hydraulic seals: - Drain valve body - Shut-off valve body:	epoxy resin coated steel brass EN 12165 CW617N, chrome plated PP EPDM brass EN 12165 CW617N -	epoxy resin coated steel brass EN 12165 CW617N stainless steel VITON brass EN 12165 CW617N, chrome plated brass EN 12165 CW617N, chrome plated
Performance: - Medium - Max. percentage glycol: - Max. working pressure: - Temperature range:	water, glycol solutions non hazardous, therefore excluded from the guidelines of 67/548/EC Directive 30% 10 bar 0-110°C	water, glycol solutions non hazardous, therefore excluded from the guidelines of 67/548/EC Directive 50% 10 bar 0-110°C
Connections: - Separator: - Front (thermometer pocket) - Automatic air vent: - Automatic air vent discharge - Drain valve	1", 1 1/4", 1 1/2" F with union 1/2" F 1/2" M - hose connection	DN 50 - 65 - 80 - 100 - 125 - 150 flanged PN 16 to be coupled with counterflanges EN 1092-1 - 3/4" F 3/8" F 1 1/4" F

Technical specifications of insulation for threaded and flanged versions DN 125 and DN 150

Internal part

- Material: closed cell expanded PE-X
- Thickness: - threaded 20 mm
- flanged 60 mm
- Density: - internal part: 30 kg/m³
- external part: 50 kg/m³ (threaded), 80 kg/m³ (flanged)
- Thermal conductivity (ISO 2581): - 0°C: 0,038 W/(m·K)
- 40°C: 0,045 W/(m·K)
- Coefficient of resistance to the diffusion of water vapour (DIN 52615): > 1.300
- Temperature range: 0–100°C
- Reaction to fire (DIN 4102): class B2

External cover (for flanged versions DN 125 and DN 150)

- Material: embossed aluminium
- Thickness: 0,70 mm
- Reaction to fire (DIN 4102): class 1

Technical specifications of insulation for flanged versions from DN 50 to DN 100

Internal part

- Material: rigid closed cell expanded polyurethane foam
- Thickness: 60 mm
- Density: 45 kg/m³
- Thermal conductivity (ISO 2581): 0,023 W/(m·K)
- Temperature range: 0 –105°C

External cover

- Material: embossed aluminium
- Thickness: 0,7 mm
- Reaction to fire (DIN 4102): class 1

Head covers

- Heat moulded material: PS

Dimensions

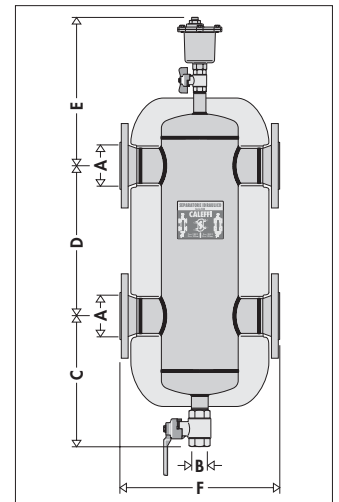
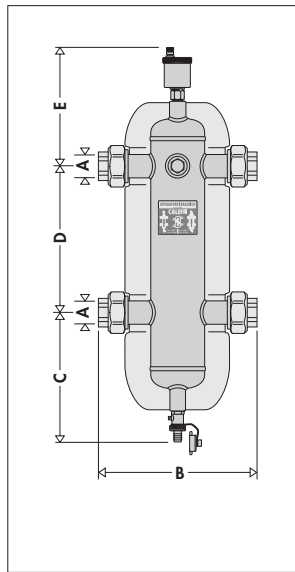

Code	A	B	C	D	E	Weight (kg)
548006	1"	225	195	220	204	2,7
548007	1 1/4"	248	225	240	214	3,8
548008	1 1/2"	282	235	260	224	5,7

Code	A	B	C	D	E	F	Weight (kg)
548052	DN 50	1 1/4"	341	330	398	350	33
548062	DN 65	1 1/4"	341	330	398	350	36
548082	DN 80	1 1/4"	389	450	440	466	49
548102	DN 100	1 1/4"	389	450	440	470	53
548122	DN 125	1 1/4"	374	560	499	635	100
548152	DN 150	1 1/4"	374	560	499	635	105

Size	1"	1 1/4"	1 1/2"	DN 50	DN 65	DN 80	DN 100	DN 125	DN 150
Volume (l)	1,7	2,6	4,8	15	15	30	30	85	88

Operating principle

When a single system contains a primary production circuit, with its own pump, and a secondary user circuit, with one or more distribution pumps, operating conditions may arise in the system whereby the pumps interact, creating abnormal variations in circuit flow rates and pressures.

The hydraulic separator creates a zone with a low pressure loss, which enables the primary and secondary circuits connected to it to be hydraulically independent of each other; **the flow in one circuit does not create a flow in the other if the pressure loss in the common section is negligible.**

In this case, the flow rate in the respective circuits depends exclusively on the flow rate characteristics of the pumps, preventing reciprocal influence caused by connection in series.

Therefore, using a device with these characteristics means that the flow in the secondary circuit only circulates when the relevant pump is on, permitting the system to meet the specific load requirements at that time.

When the secondary pump is off, there is no circulation in the secondary circuit; the whole flow rate produced by the primary pump is by-passed through the separator.

With the hydraulic separator, it is thus possible to have a production circuit with a constant flow rate and a distribution circuit with a variable flow rate; these operating conditions are typical of modern heating and air-conditioning systems.

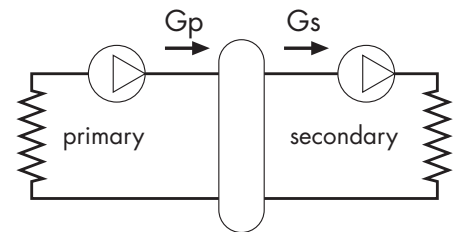

Three possible hydraulic balance situations are shown below.

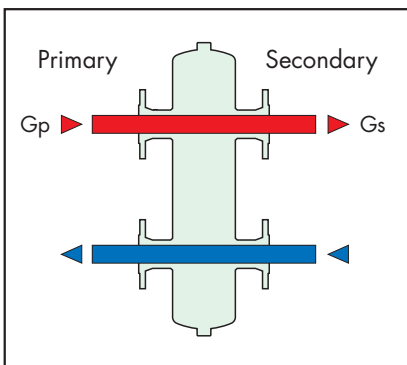

$G_{primary} = G_{secondary}$

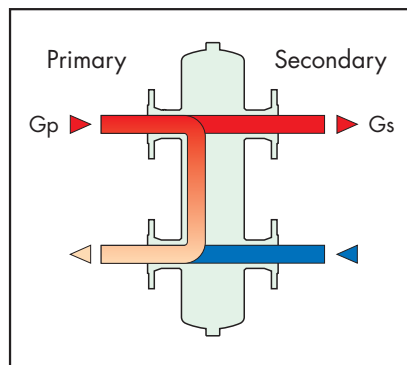

$G_{primary} > G_{secondary}$

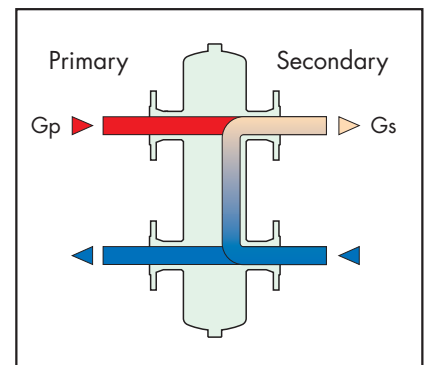

$G_{primary} < G_{secondary}$

Construction details

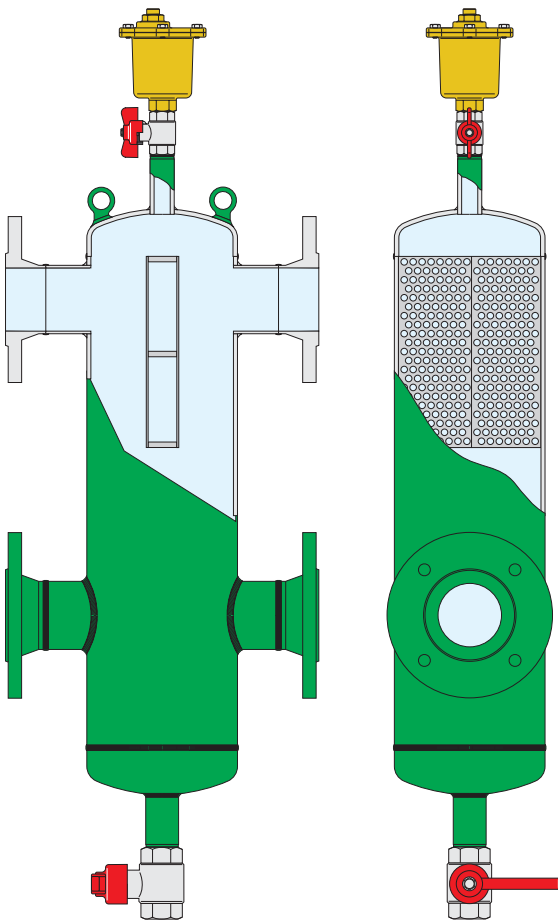

Isolating the air vent valve

In flanged separators, the air vent is isolated manually, using a ball valve. In threaded separators, however, the air vent body is automatically isolated by the built-in valve, which closes when the air vent body is removed.

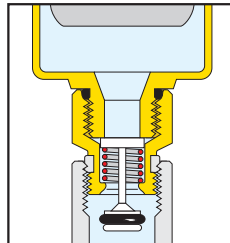

Dirt removing element

A vital function of the hydraulic separator is carried out by the dirt removing element inside the device. This makes it possible to separate and collect any impurities which may be present in the system.

These impurities are removed by means of the drain valve, which can be connected to a discharge pipe, placed at the bottom of the separator.

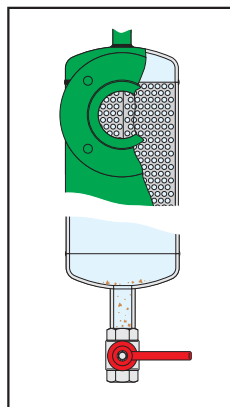

Insulation

Flanged versions separators up to DN 100 are available complete with the insulation made of a shell in expanded polyurethane foam coated with an aluminium layer. For threaded and flanged versions DN 125 and DN 150, insulation is made of a pre-formed shell in closed cell expanded PE-X.

This insulation ensures not only perfect heat insulation but also the tightness required to prevent atmospheric water vapour from entering the unit. For these reasons, this type of insulation can also be used in cooling water circuits, as it prevents the formation of condensate on the surface of the valve body.

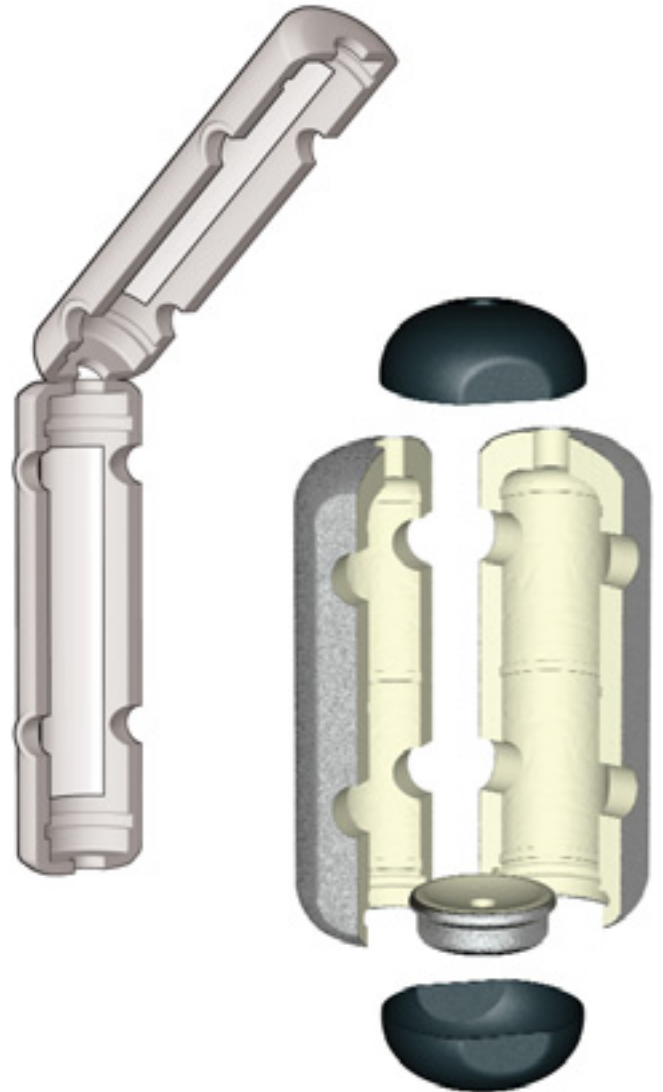

Hydraulic characteristics

The hydraulic separator should be sized according to the maximum flow rate value at the inlet. The selected design value must be the greatest between the primary circuit and the secondary circuit.

Size	Flow rate m ³ /h
1"	2,5
1 1/4"	4
1 1/2"	6

Size	Flow rate m ³ /h
DN 50	9
DN 65	18
DN 80	28
DN 100	56
DN 125	75
DN 150	110

Application diagram

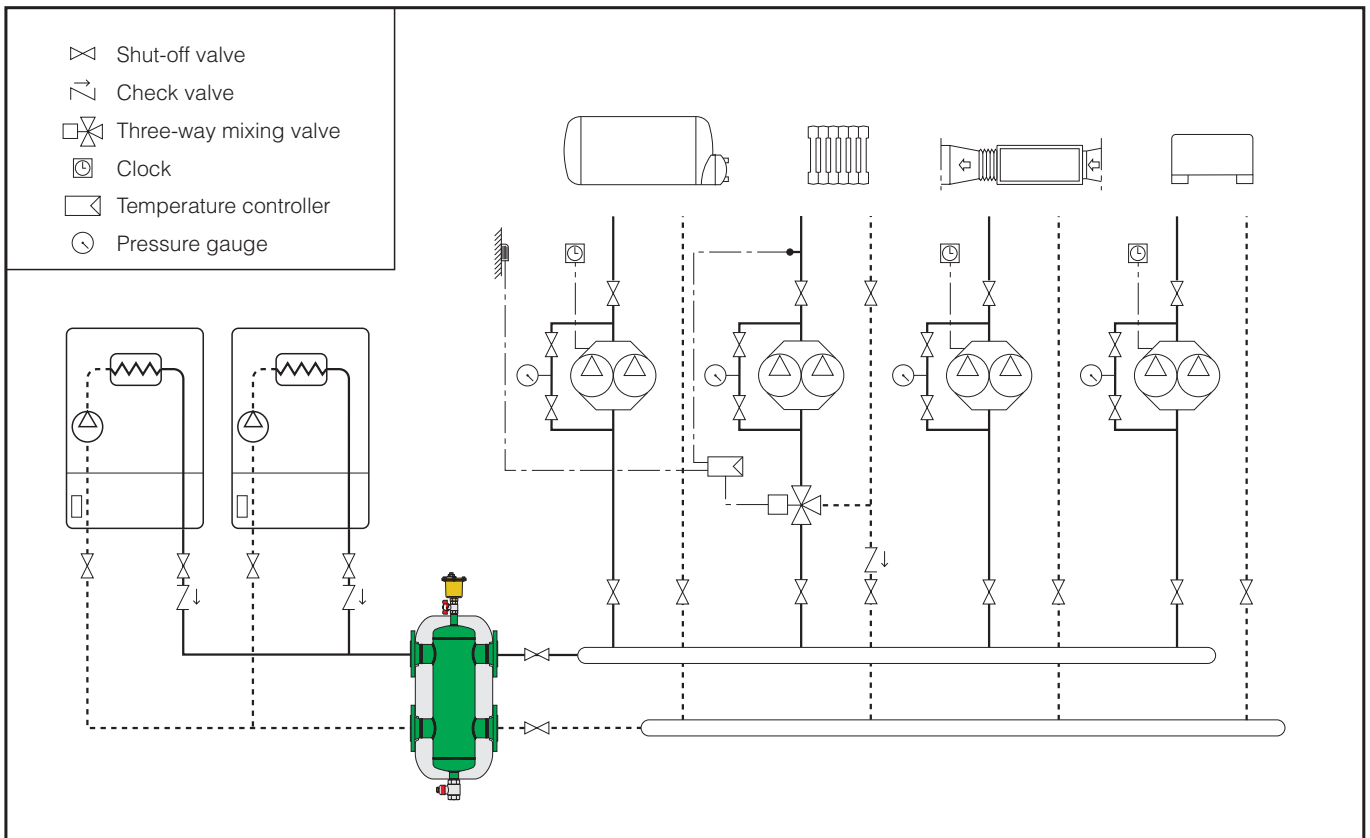

SPECIFICATION SUMMARIES

548 series

Hydraulic separator. Connections 1" F (from 1" to 1 1/2") with union. Front connection 1/2" F (thermometer pocket). Epoxy resin coated steel body. Medium: water, glycol solutions non hazardous, therefore excluded from the guidelines of 67/548/EC Directive. Maximum percentage of glycol: 30%. Maximum working pressure: 10 bar. Temperature range: 0–110°C.

Supplied with:

- Automatic air vent valve. 1/2" M connection. Brass body, chrome plated. PP float. EPDM hydraulic seals.
- Drain valve. Hose connection. Brass body.
- Hot pre-formed shell insulation in closed cell expanded PE-X. Temperature range: 0–100°C.

548 series

Hydraulic separator. Flanged connections DN 50 (from DN 50 to DN 150) PN 16, to be coupled with counterflanges EN 1092-1. Epoxy resin coated steel body. Medium: water, glycol solutions non hazardous, therefore excluded from the guidelines of 67/548/EC Directive. Maximum percentage of glycol: 50%. Maximum working pressure: 10 bar. Temperature range: 0–110°C.

Supplied with:

- Automatic air vent valve. 3/4" F connection. 3/8" F discharge connection. Brass body. Stainless steel float. VITON hydraulic seals.
- Drain valve. 1 1/4" F connection. Brass body, chrome plated.
- Rigid closed cell expanded polyurethane foam shell insulation to DN 100 (closed cell expanded PE-X for DN 125 and DN 150). External embossed aluminium cover. Temperature range: 0–105°C (0–100°C for DN 125 and DN 150).

We reserve the right to change our products and their relevant technical data, contained in this publication, at any time and without prior notice.

