

Thermostatic mixing valves with interchangeable cartridges

5230 Series

Installation, commissioning and servicing instructions



ASSE 1017

ASSE 1070

Function

The thermostatic mixing valve is used in systems producing domestic hot water or in radiant panel heating systems. Its function is to maintain the temperature of the mixed water supplied to the user at a constant set value when there are variations in the supply pressure and temperature of the incoming hot and cold water or in the flow rate.

Valve models with integral inlet port check valves are ASSE 1070 approved for point of use installations. Models without check valves are ASSE 1017 approved for point of distribution and are designed specifically for systems requiring high flow rates and precise, stable temperature control.

Patent Pending N. MI2001A001645.

Product range

5230 series thermostatic mixing valve. Union thread NPT male and union sweat connections, sizes 1/2", 3/4", 1", 1 1/4", 1 1/2", 2".

Technical Characteristics

- Materials:
 - Body: Brass
 - Shutter: Brass, chemical nickel plated
 - Springs: Stainless steel
 - Seals: EPDM
- Medium: Water
- Maximum percentage of glycol: 30% glycol solution
- Setting range: See table at page 2
- Temperature stability: $\pm 5^{\circ}\text{F}$ ($\pm 3^{\circ}\text{C}$)
- Max working pressure (static): 200 psi (14 bar)
- Max working pressure (dynamic): 70 psi (5 bar)
- Hot water inlet temperature range: 120 – 185°F (49 – 85°C)
- Cold water inlet temperature range: 40 – 80°F (4.4 – 26.6°C)
- Maximum inlet pressure ratio (H/C or C/H): 2:1
- Minimum temperature difference between hot water inlet and mixed water outlet for optimum performance: 20°F (11°C)
- Maximum water hardness: 10 grains
- Approved for ASSE 1017 and 1070 depending on model

**Point of Use
ASSE 1070
Approved***

(packaged with pipe fittings and check valves)

| Code | Description | Flow |
|---------|----------------------------|--------|
| 523045A | 1/2" Union Thread NPT male | 4.8 Cv |
| 523047A | 1/2" Union Sweat | 4.8 Cv |
| 523055A | 3/4" Union Thread NPT male | 4.8 Cv |
| 523057A | 3/4" Union Sweat | 4.8 Cv |
| 523065A | 1" Union Thread NPT male | 4.8 Cv |
| 523067A | 1" Union Sweat | 4.8 Cv |

Setting the temperature

The temperature is set to the required value by means of the adjusting knob with the graduated scale on the top of the valve.

| Pos. | Min | 1 | 2 | 3 | 4 | 5 | 6 | 7 | Max |
|--------|-----|----|----|-----|-----|-----|-----|-----|-----|
| T (°F) | 77 | 84 | 91 | 102 | 109 | 118 | 126 | 136 | 149 |
| T (°C) | 25 | 29 | 33 | 39 | 43 | 48 | 52 | 58 | 65 |

with: $T_{HOT} = 155^{\circ}F (68^{\circ}C)$ · $T_{COLD} = 55^{\circ}F (13^{\circ}C)$ · $P = 43 \text{ psi (3 bar)}$

Replacement Cartridge code 523005

Replacement Fitting Part Numbers

| Code | Description | Tailpiece Inlet Ports (2) | Tailpiece Outlet Port (1) | Check Valves (2) | Union nuts (3) | Gaskets (3) |
|---------|----------------------------|---------------------------|---------------------------|------------------|----------------|-------------|
| 523045A | 1/2" Union Thread NPT male | NA10111 | NA10111 | NA10117 | R31495 | R50056 |
| 523047A | 1/2" Union Sweat | NA10112 | NA10112 | | | |
| 523055A | 3/4" Union Thread NPT male | NA10113 | NA10113 | | | |
| 523057A | 3/4" Union Sweat | NA10114 | 31390 FD | | | |
| 523065A | 1" Union Thread NPT male | NA10116 | NA10116 | | | |
| 523067A | 1" Union Sweat | NA10115 | NA10042 | | | |

*packaged with pipe fittings and check valves for field installation. Each valve requires 2, one in each inlet port, and all valve sizes use check valve NA10117.

Recommended flow rates for temperature stability:

| | Min. (gpm) | Max. (gpm) |
|-------------|------------|------------|
| 1/2" - 3/4" | 2 | 24 |
| 1" | | |

Flow curve

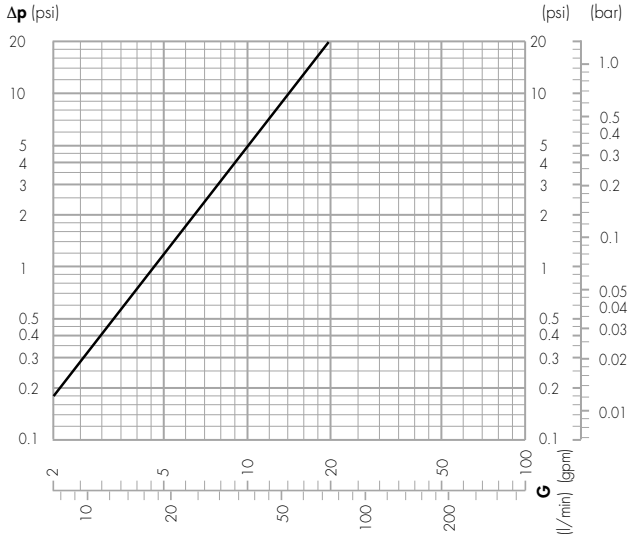

1/2, 3/4, and 1 inch sizes use the same body, differing only by inlet/outlet fittings, have the same max Cv of 4.8 and one flow curve.

**Point of
Distribution
ASSE 1017
Approved**

| Code | Description | Flow |
|-------------|----------------------------|-------------|
| 523040A | 1/2" Union Thread NPT male | 4.8 Cv |
| 523048A | 1/2" Union Sweat | 4.8 Cv |
| 523050A | 3/4" Union Thread NPT male | 4.8 Cv |
| 523058A | 3/4" Union Sweat | 4.8 Cv |
| 523066A | 1" Union Sweat | 4.8 Cv |

Setting the temperature

The temperature is set to the required value by means of the adjusting knob with the graduated scale on the top of the valve.

| Pos. | Min | 1 | 2 | 3 | 4 | 5 | 6 | 7 | Max |
|--------|-----|----|----|-----|-----|-----|-----|-----|-----|
| T (°F) | 77 | 84 | 91 | 102 | 109 | 118 | 126 | 136 | 149 |
| T (°C) | 25 | 29 | 33 | 39 | 43 | 48 | 52 | 58 | 65 |

with: $T_{HOT} = 155^{\circ}F (68^{\circ}C)$ · $T_{COLD} = 55^{\circ}F (13^{\circ}C)$ · $P = 43 \text{ psi (3 bar)}$

Replacement Cartridge code 523005

| Code | Description | Flow |
|-------------|------------------------------|-------------|
| 523060A | 1" Union Thread NPT male | 8 Cv |
| 523068A | 1" Union Sweat | 8 Cv |
| 523070A | 1-1/4" Union Thread NPT male | 10 Cv |
| 523078A | 1-1/4" Union Sweat | 10 Cv |

| Pos. | Min | 1 | 2 | 3 | 4 | 5 | 6 | 7 | Max |
|--------|-----|----|-----|-----|-----|-----|-----|-----|-----|
| T (°F) | 81 | 90 | 100 | 111 | 120 | 127 | 136 | 145 | 153 |
| T (°C) | 27 | 32 | 38 | 44 | 49 | 53 | 58 | 63 | 67 |

with: $T_{HOT} = 155^{\circ}F (68^{\circ}C)$ · $T_{COLD} = 55^{\circ}F (13^{\circ}C)$ · $P = 43 \text{ psi (3 bar)}$

Replacement Cartridge code 523006

| Code | Description | Flow |
|-------------|------------------------------|-------------|
| 523080A | 1-1/2" Union Thread NPT male | 17 Cv |
| 523090A | 2" Union Thread NPT male | 22 Cv |

| Pos. | Min | 1 | 2 | 3 | 4 | 5 | 6 | 7 | Max |
|--------|-----|-----|-----|-----|-----|-----|-----|-----|-----|
| T (°F) | 97 | 102 | 108 | 113 | 118 | 126 | 129 | 135 | 140 |
| T (°C) | 36 | 39 | 42 | 45 | 48 | 52 | 54 | 57 | 60 |

with: $T_{HOT} = 155^{\circ}F (68^{\circ}C)$ · $T_{COLD} = 55^{\circ}F (13^{\circ}C)$ · $P = 43 \text{ psi (3 bar)}$

Replacement Cartridge code 523008

Replacement Fitting Part Numbers

| Code | Description | Tailpiece All Ports (3) | Union nuts (3) | Gaskets (3) |
|-------------|------------------------------|------------------------------------|---------------------------|--------------------|
| 523040A | 1/2" Union Thread NPT male | NA10111 | R31495 | R50056 |
| 523048A | 1/2" Union Sweat | NA10112 | | |
| 523050A | 3/4" Union Thread NPT male | NA10113 | | |
| 523058A | 3/4" Union Sweat | 31390 FD | | |
| 523066A | 1" Union Sweat | NA10042 | R31589 | R50057 |
| 523060A | 1" Union Thread NPT male | NA10069 | | |
| 523068A | 1" Union Sweat | NA10010 | | |
| 523070A | 1-1/4" Union Thread NPT male | NA10011 | | |
| 523078A | 1-1/4" Union Sweat | NA10012 | R51838 | R50060 |
| 523080A | 1-1/2" Union Thread NPT male | 41371A | | |
| 523090A | 2" Union Thread NPT male | 41372A | | |

Recommended flow rates for temperature stability:

| | Min. (gpm) | Max. (gpm) |
|-----------------------|------------|------------|
| 1/2" - 3/4" | 2 | 24 |
| 1" (523066A) | | |
| 1" 523060A 523068A | 4.5 | 40 |
| 1 1/4" | 13 | 83 |
| 1 1/2" | | |
| 2" | | |

Flow curves

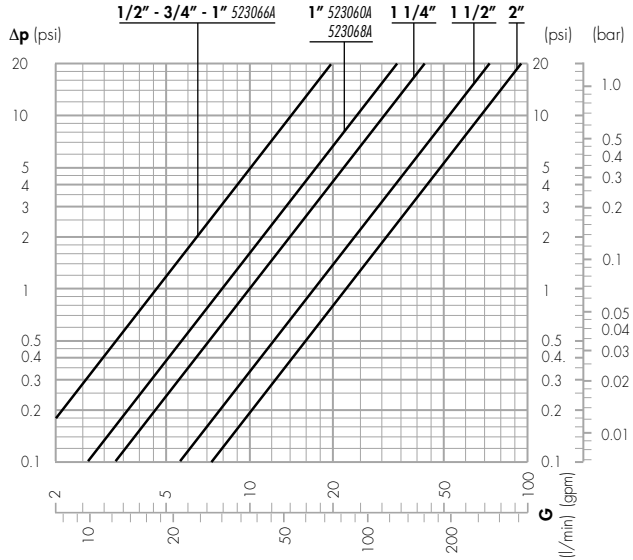

Principle of Operation

A thermostatic mixing valve mixes hot and cold water in such a way as to maintain a constant set temperature of the mixed water at the outlet. A thermostatic element is fully immersed into the mixed water. It then contracts or expands causing movement of the piston, closing either the hot or cold inlets, regulating the flow rates entering the valve. If there are variations of temperature or pressure at the inlets, the internal element automatically reacts attempting to restore the original temperature setting.

Thermal shutoff

In the event of a failure of either the hot or cold supply, the piston will shut off, stopping water discharging from the mixed water outlet. The Caleffi 5230 series mixing valve requires a minimum temperature differential from hot inlet to mixed water outlet of 20°F (11°C) to ensure the correct operation of the thermal shutoff feature. Softened water use is highly recommended as the warranty is voided if used on water with hardness greater than 10 grains.

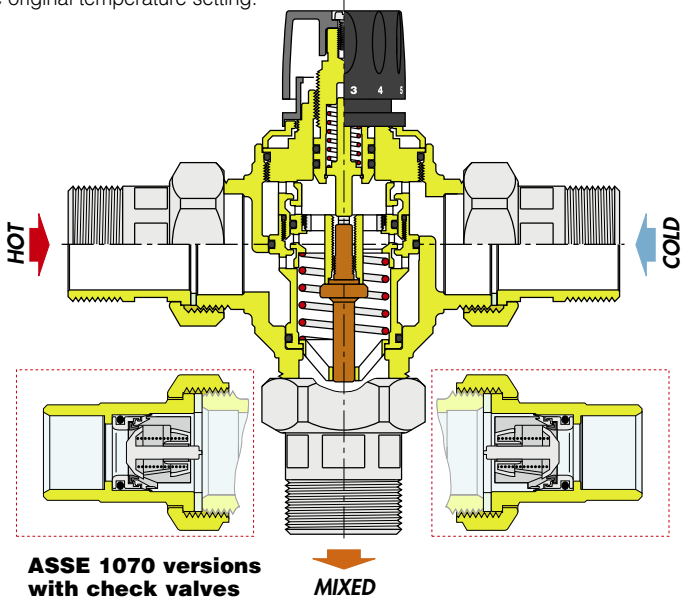



SAFETY INSTRUCTION

This safety alert symbol will be used in this manual to draw attention to safety related instructions. When used, the safety alert symbol means **ATTENTION! BECOME ALERT! YOUR SAFETY IS INVOLVED! FAILURE TO FOLLOW THESE INSTRUCTIONS MAY RESULT IN A SAFETY HAZARD.**



CAUTION: All work must be performed by qualified personnel trained in the proper application, installation, and maintenance of systems in accordance with all applicable codes and ordinances.



CAUTION: If the thermostatic mixing valve is not installed, commissioned and maintained properly, according to the instructions contained in this manual, it may not operate correctly and may endanger the user.



CAUTION: Make sure that all the connecting pipework is water tight.



CAUTION: When making the water connections, make sure that the mixing valve connecting pipework is not mechanically over-stressed. Over time this could cause breakages, with consequent water losses which, in turn, could cause harm to property and/or people.



CAUTION: Water temperatures higher than 100°F can be dangerous. During the installation, commissioning and maintenance of the thermostatic mixing valve, take the necessary precautions to ensure that such temperatures do not endanger people.



CAUTION: In the case of highly aggressive water, arrangements must be made to treat the water before it enters the thermostatic mixing valve, in accordance with current legislation. Otherwise the mixing valve may be damaged and will not operate correctly.

Leave this manual for the user.

Use



Caleffi 5230 series thermostatic mixing valves are designed to be installed at the hot water heater (ASSE 1017 models) or at the point of distribution (ASSE 1070 models).

ASSE 1017 models are designed to be installed at the hot water heater and cannot be used for tempering water temperature at fixtures as a point-of-use valve. They are not designed to provide antiscald or anti-chill service and should not be used where ASSE 1070 devices are required. Wherever an antiscald feature is required, ASSE 1070 model mixing valves need to be installed. For safety reasons, it is advisable to limit the maximum mixed water temperature to 120°F.

ASSE 1070 models are suitable for point of use application. For this reason the flow rate through the valve is the same as that of the final outlet, e.g. mixing valve or tap for washbasin, shower or bath. The system must be sized taking into account the current legislation with regard to the nominal flow rate of each outlet.

Instantaneous production of hot water

Caleffi 5230 series thermostatic mixing valves should not be used in conjunction with boilers giving instantaneous production of domestic hot water. Their addition would compromise the correct operation of the boiler itself.

Installation

Before installing a Caleffi 5230 series thermostatic mixing valve, the system must be inspected to ensure that its operating conditions are within the range of the mixing valve, checking, for example, the supply temperature, supply pressure, etc.



Systems where the Caleffi 5230 series thermostatic mixing valve is to be fitted must be drained and cleaned out to remove any dirt or debris which may have accumulated during installation.

Failure to remove dirt or debris may affect performance and the manufacturer's product guarantee. Softened water use is highly recommended as the warranty is voided if used on water with hardness greater than 10 grains.

The installation of filters of appropriate capacity at the inlet of the water from the mains supply is always advisable.

In areas which are subject to highly aggressive water, arrangements must be made to treat the water before it enters the valve.

Caleffi 5230 series thermostatic mixing valves must be installed in accordance with the diagrams in this manual, taking into account all current applicable standards.

Caleffi 5230 series thermostatic mixing valves can be installed in any position, either vertical or horizontal.

The following are shown on the mixing valve body:

- Hot water inlet, color red.
- Cold water inlet, color blue.
- Mixed water outlet, marked "MIX".

In systems with thermostatic mixing valves, check valves must be installed to prevent undesirable fluid backflow. The 5230- 1017 models do not contain integral check valves, so those must be sourced separately. The 5230 - 1070 models come with check valves that must be installed in the field. See Installation instructions.

It is essential that access to the valve is totally unobstructed for any maintenance which may be required to the valve or connections. The pipework from/to the valve must not be used to support the weight of the valve itself.

Field installation of check valves provided with the Caleffi 5230 models approved for ASSE 1070: Check valves prevent the backflow of hot water into the cold branch, and cold water into the hot branch through the 5230 valve. Union sweat connections should be soldered prior to assembly to the valve, or without the sealing gasket or plastic check valve present. The sweat tailpiece must be soldered onto the piping, then cooled down before the check valves are installed. A moistened rag works well for cooling and cleaning the soldered joints. Be sure to slide the nut onto the tailpiece before it is placed on the tube and soldered. Do not attempt to solder or heat the sweat connection with the check valves or the thermostatic mixing valve installed. Also, flush any solder or flux residue from the piping before assembling the check and valve into the piping.



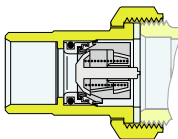

ASSE 1070 versions with check valves

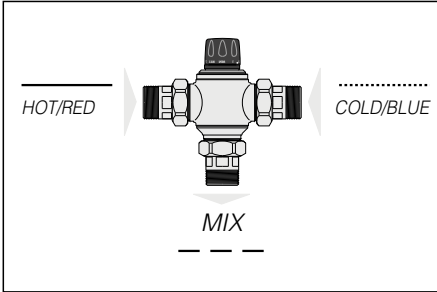

Application Diagrams



Key to symbols

-  Safety relief valve
-  Check valve
-  Isolation valve
-  Expansion vessel
-  Filter

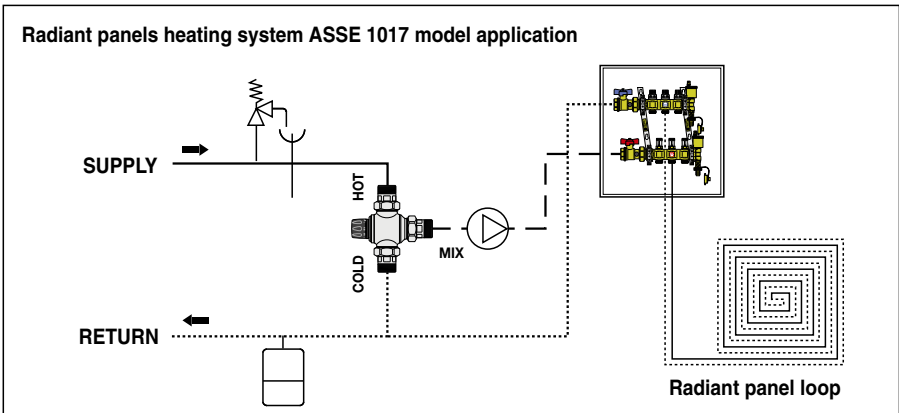
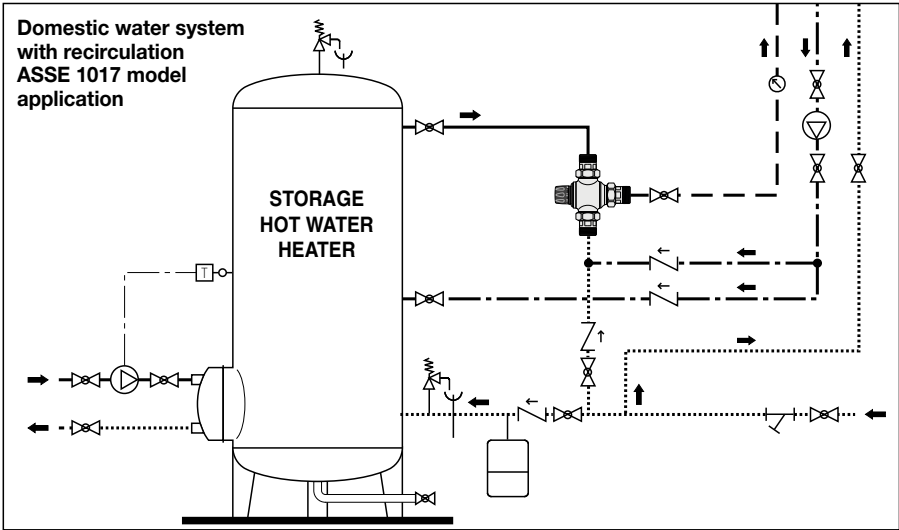

Application Diagrams

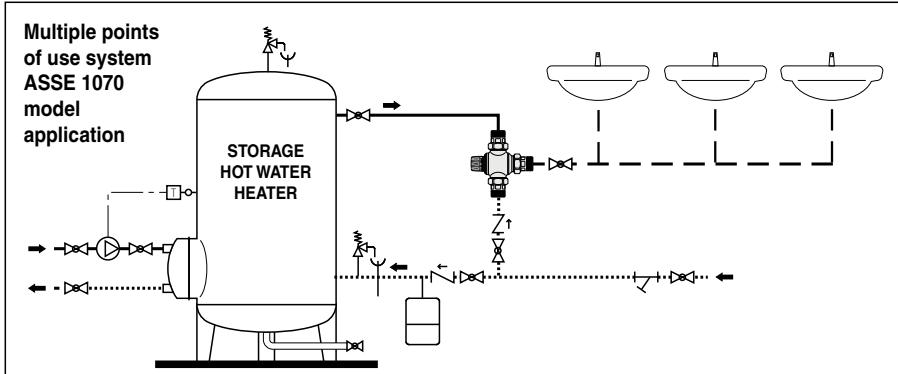

Commissioning

After installation, the valve must be tested and commissioned in accordance with the instructions given below, taking into account current applicable standards.

- 1) Ensure that the system is clean and free from any dirt or debris before commissioning the thermostatic mixing valve. Be sure water hardness is less than 10 grains.
- 2) It is recommended that the temperature is set using a suitable calibrated digital thermometer. The valve must be commissioned by measuring the temperature of the mixed water at the outlet.
- 3) The maximum outlet temperature from the valve must be set taking account of the fluctuations due to simultaneous use. It is essential for these conditions to be stabilised before commissioning.
- 4) Adjust the temperature using the adjusting knob on the valve. For safety reasons, it is advisable to limit the maximum mixed water temperature to 120°F in domestic hot water systems.

Preset locking

Position the handle to the number required. Unscrew the head screw, pull off the handle and reposition it so that the handle fits into the internal slot of the knob. Tighten the head screw.

Maintenance

Service tests should be carried out regularly to monitor the mixing valve performance, as deterioration of performance could indicate that the valve and/or the system require maintenance. If, during these tests, the temperature of the mixed water has changed significantly in comparison with the previous test, the details given in the installation and commissioning sections should be checked and maintenance carried out. The following aspects should be checked regularly to ensure that the optimum performance levels of the valve are maintained. Every 12 months at least, or more often if necessary.

- 1) Check and clean the system filters.
- 2) Check that any non-return valves positioned upstream of the Caleffi valve are operating correctly, without problems caused by impurities.
- 3) Limescale can be removed from internal components by immersion in a suitable de-scaling fluid.
- 4) When the components which can be maintained have been checked, commissioning should be carried out again.

Cartridge Replacement

The internal cartridge containing all the regulating components can be inspected and, if necessary, replaced, without dismantling the valve body from the pipework.

- 1) Close the shut-off valves on the hot and cold inlets. Set the knob on the maximum position.
- 2) Remove the temperature adjusting knob after unscrewing the lock screw on the top. Dismantle the plastic knob frame. Unscrew the chromed protective cap (1" - 1 1/4").
- 3) Remove the internal cartridge for inspection or replacement, using a suitably sized spanner.
- 4) Re-assemble the chromed protective cap. Re-assemble the knob frame in such a way that the position indicator can be seen.
- 5) The spare cartridge is supplied pre-set to the maximum value. Position the adjusting knob in such a way that the word MAX lines up with the position indicator. By turning the knob clockwise, it should be possible to adjust from the maximum value to the minimum value. Fix the knob with the lock screw.
- 6) Adjust the mixing valve to the desired temperature by following the commissioning procedure.

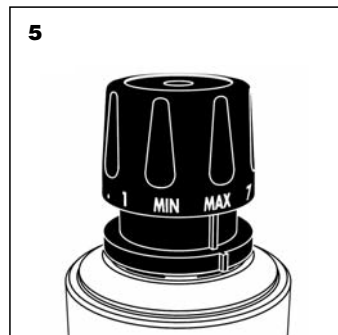
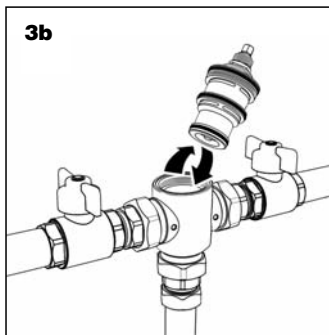
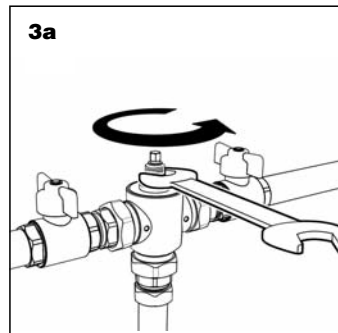
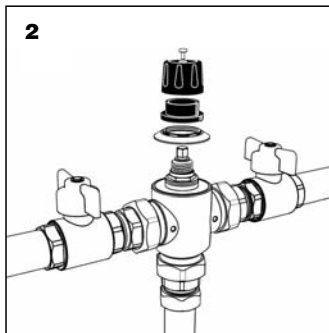

Troubleshooting

Under normal operating conditions the Caleffi 5230 series thermostatic mixing valve will provide a very high level of performance. However, in some circumstances, where our maintenance plan is not followed, the following problems may arise.

| Symptom | Cause | Corrective action |
|--------------------------------------|---|--|
| Hot water at the cold taps | a) Operation of check valve is hindered; check valve is not sealing correctly. b) Check valves not fitted. | <ul style="list-style-type: none">• Replace faulty check valves |
| Fluctuating mixed water temperature | a) Erratic supply temperatures at the inlets of the valve. b) Starvation of the water supplies at the inlets of the valve. c) Incorrect commissioning of the valve. | <ul style="list-style-type: none">• Restore inlet conditions within the limits of the valve. |
| Erratic flow of water from the valve | a) Insufficient water supplies. b) Fluctuations in supply pressures/temperatures. c) Adverse effect created by other draw off points on the system. | <ul style="list-style-type: none">• Stabilize inlet supply conditions. |
| No flow of water from the valve | a) In-line filters blocked. b) Insufficient supply pressures. c) Debris obstructing valve operation. | <ul style="list-style-type: none">• Clean filters.• Restore inlet supplies.• Clean debris or scale from valve. |



Caleffi North America, Inc.
3883 W. Milwaukee Road
Milwaukee, WI 53208
T: 414.238.2360 F: 414.238.2366